



EUBCE 2026
34th European Biomass Conference & Exhibition

Strategic Planning and Simulation of Biomass Integration into District Heating Networks

An Integrated Approach for the Fossil Phase Out in Gleisdorf, Austria

34th European Biomass Conference & Exhibition,
The Hague, The Netherlands

Xhoi Zhupani, Franz Mauthner, Joachim Kelz

AEE – Institute for Sustainable Technologies (AEE INTEC)
8200 Gleisdorf, Feldgasse 19, Österreich

Motivation and Background

- **Heating sector accounting to 50% of energy consumption in EU**
 - Still fossil-dominated
 - Key driver of the energy transition
 - High relevance for EU-strategies
- **District heating networks enable**
 - Strategic heating solution for fossil phase-out
 - Integration of renewable and locally available sources like biomass, solar, waste heat ...
 - Support local heat planning of municipalities

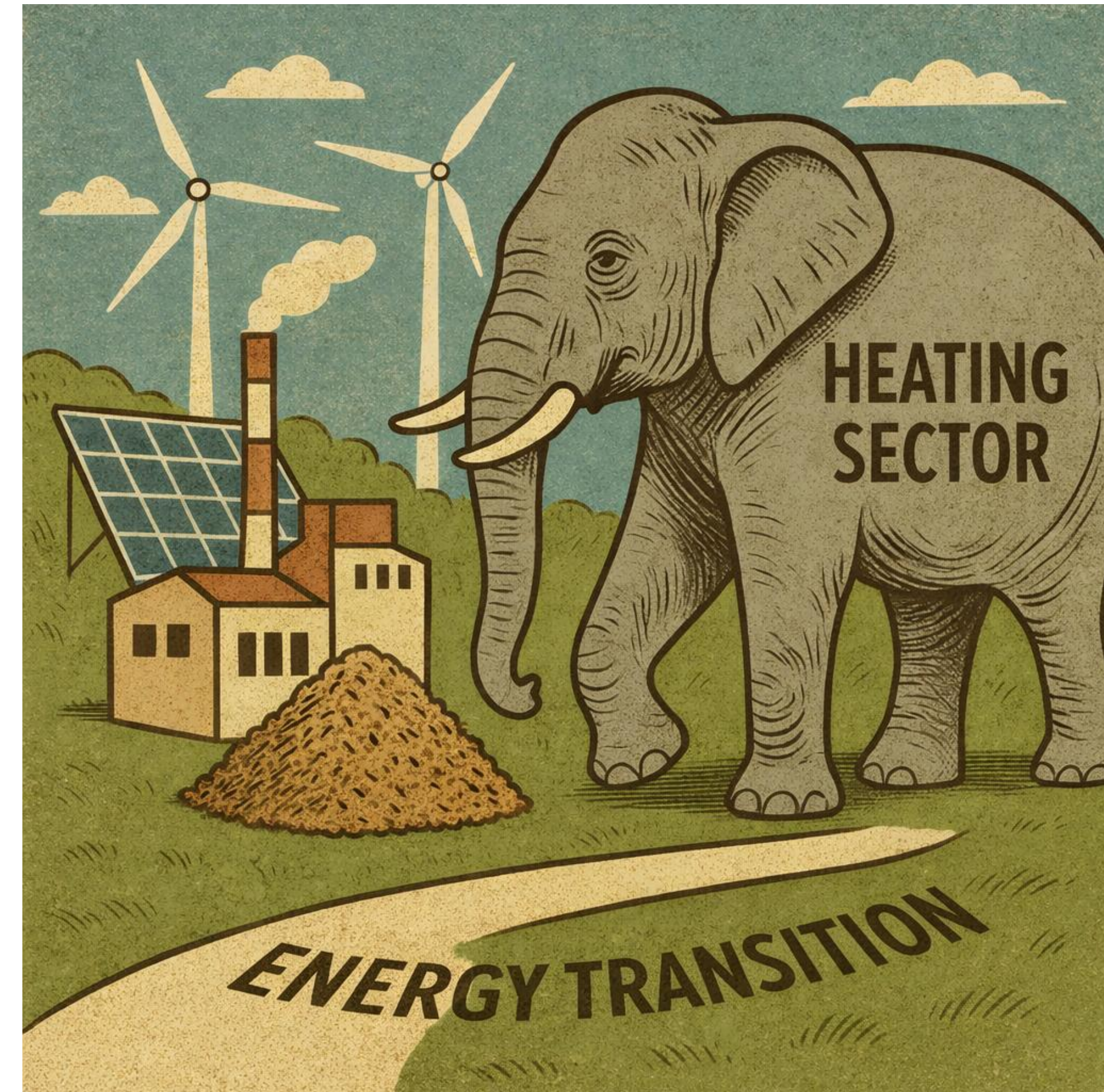

Source: AI generated / AEE INTEC

Challenges and main goals

Challenges

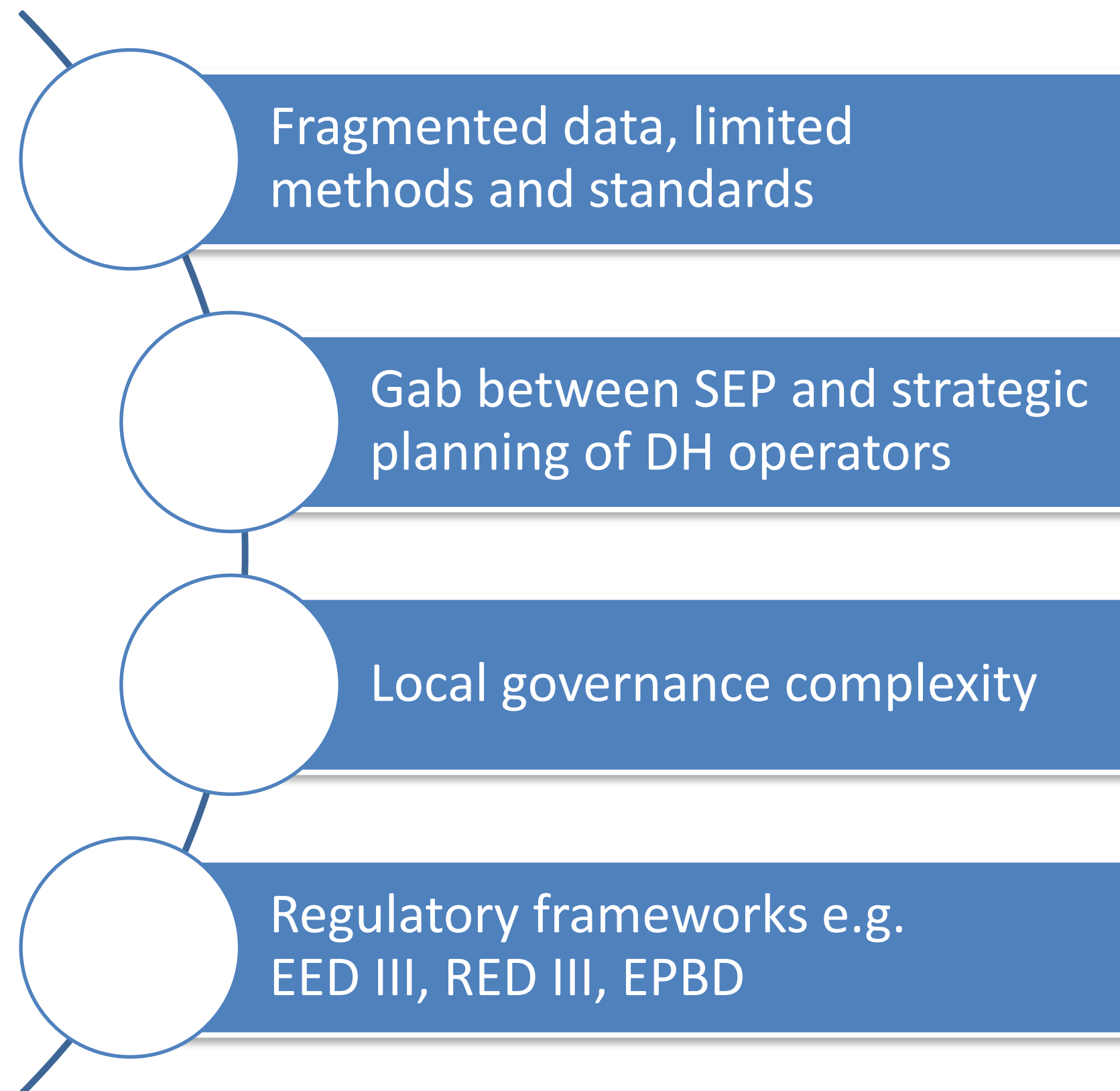

Main Goals

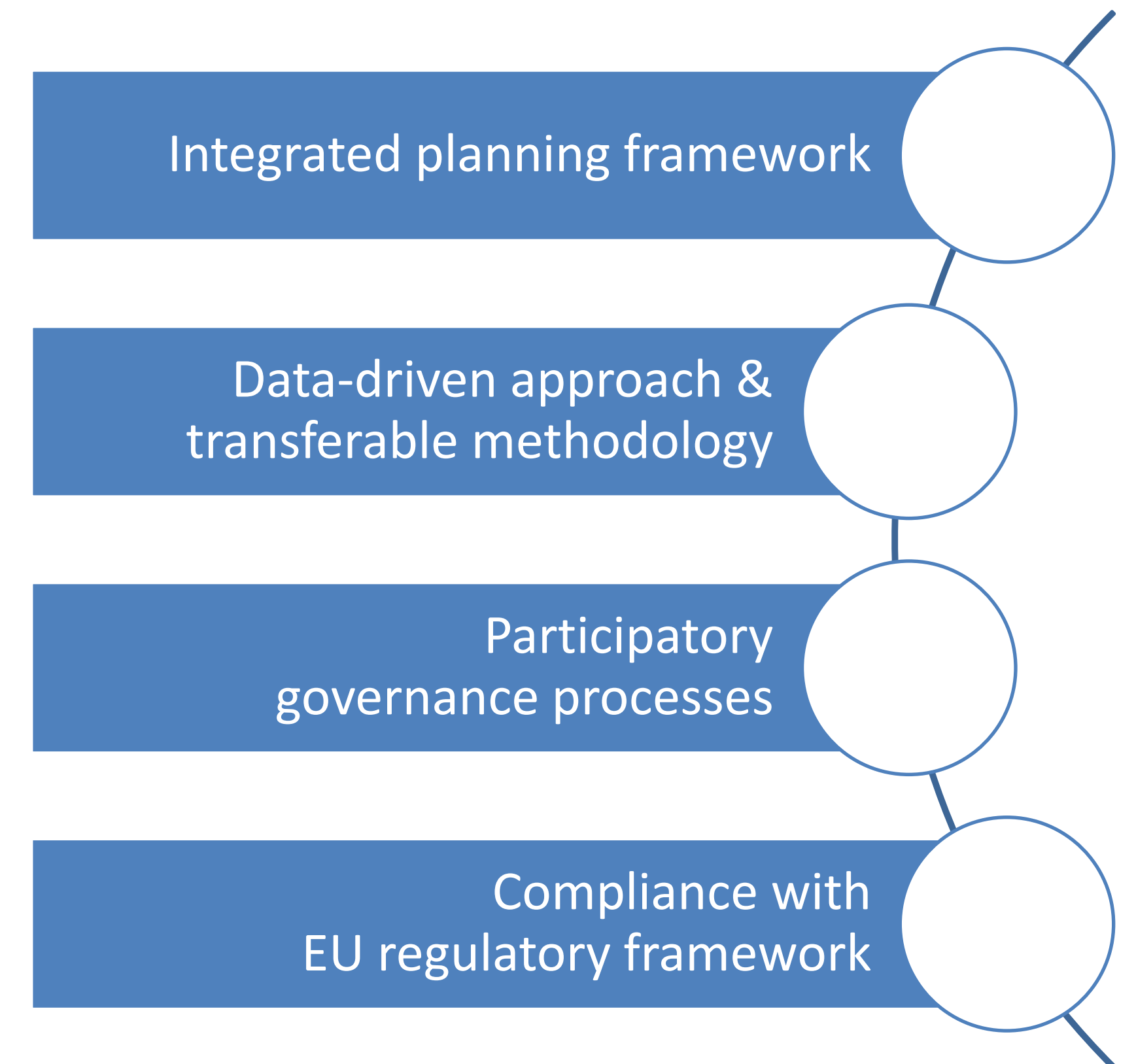

Methodology applied

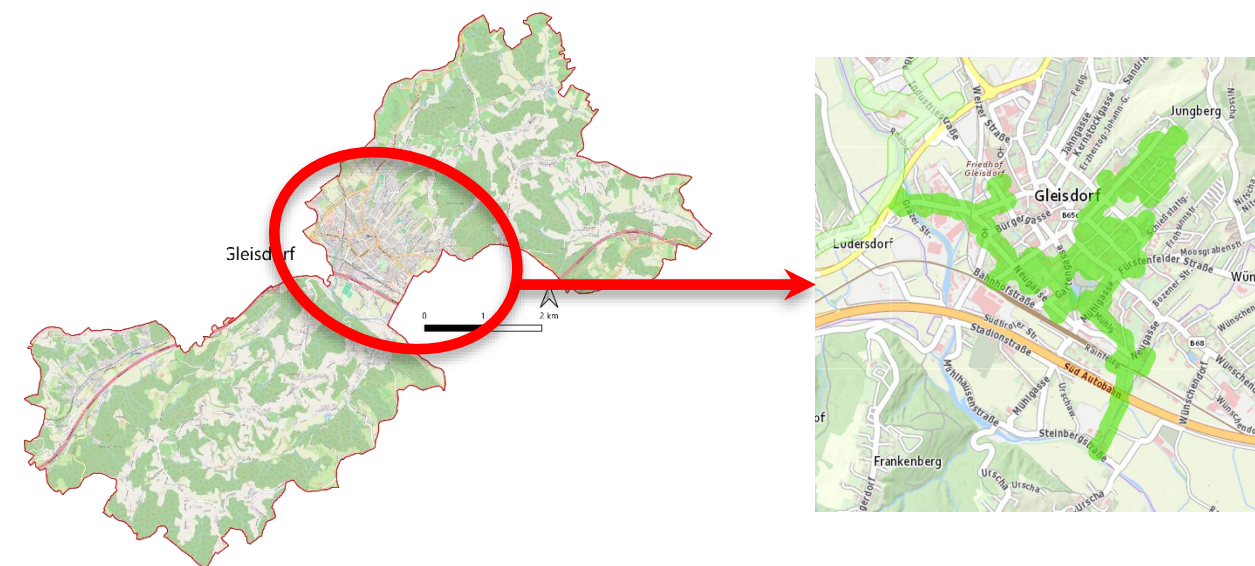

Status quo evaluation / data acquisition

Energy model development

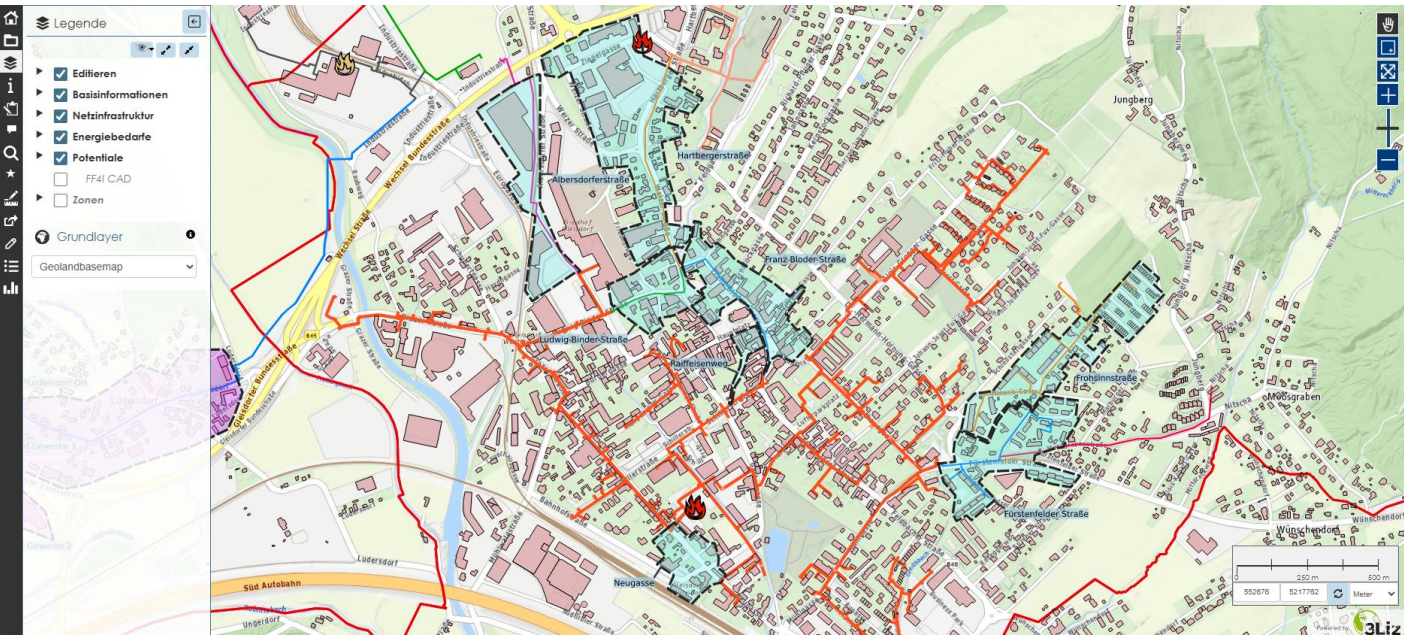
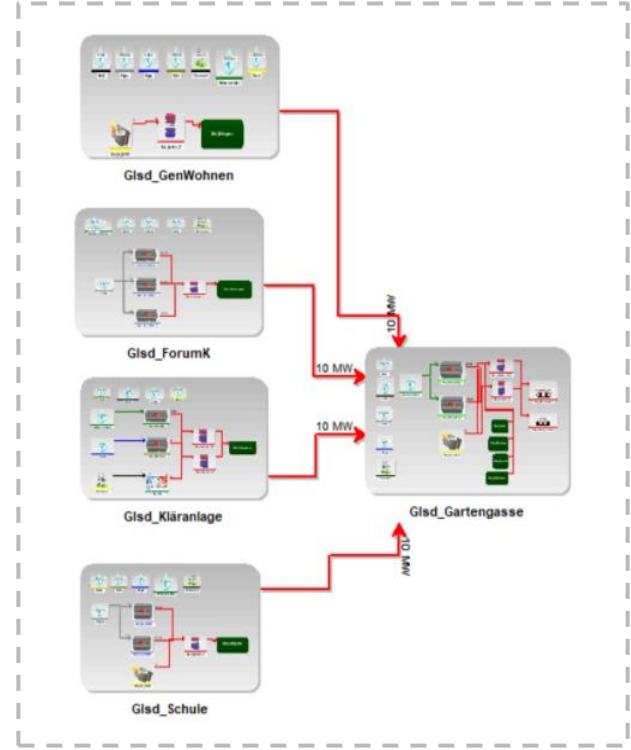

GIS based analysis (Areas of Interest)

Fossil phase-out scenario design

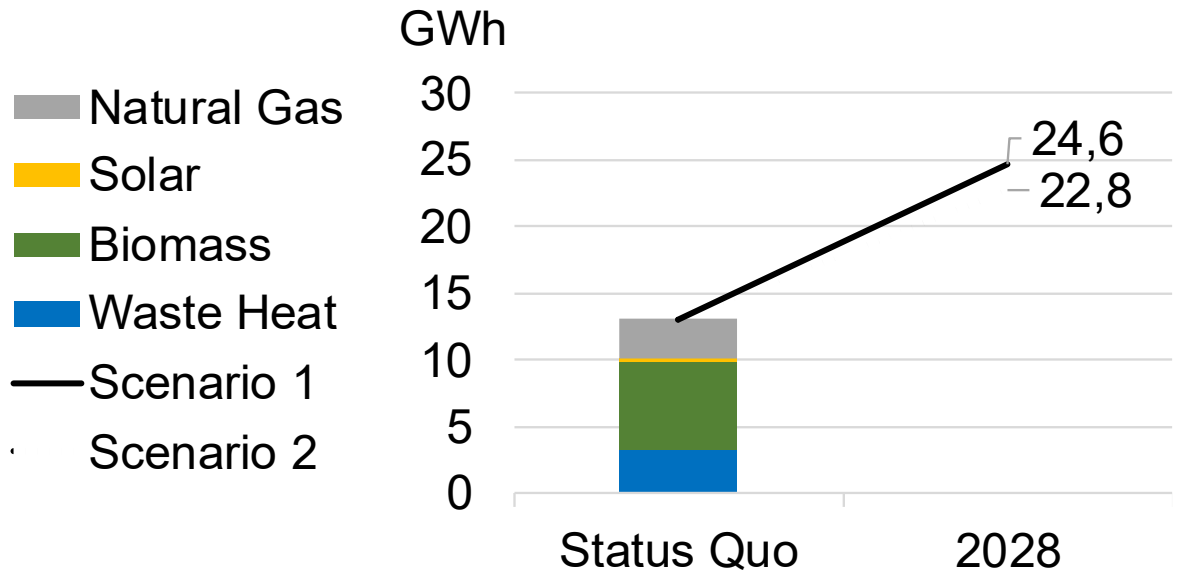

Simulation and validation

Overall evaluation

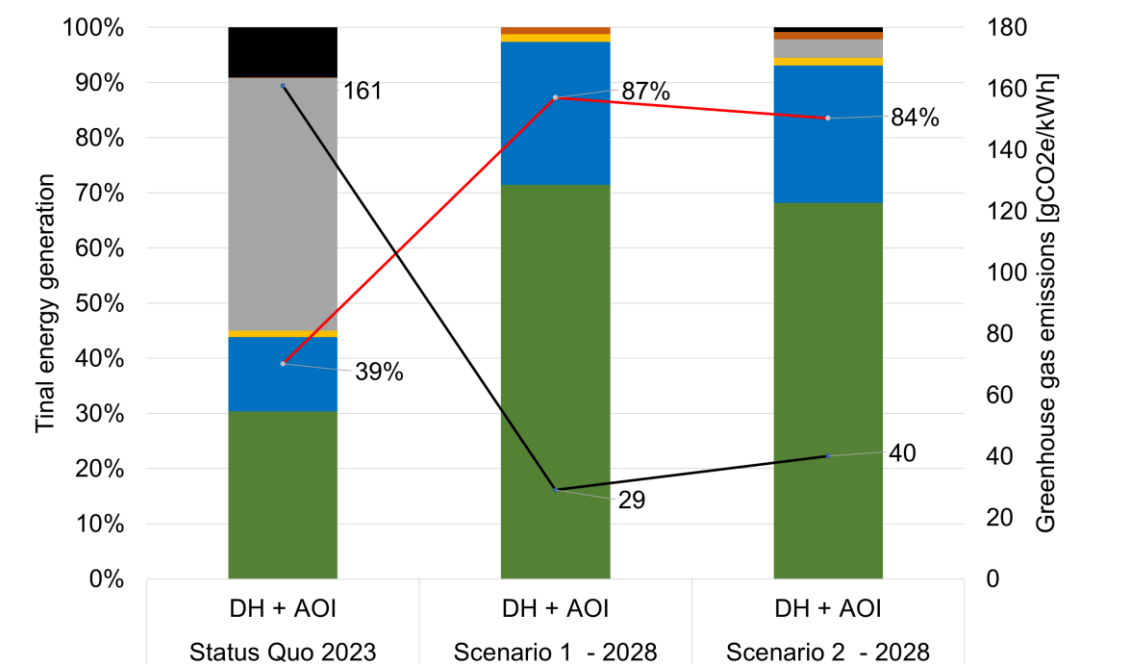
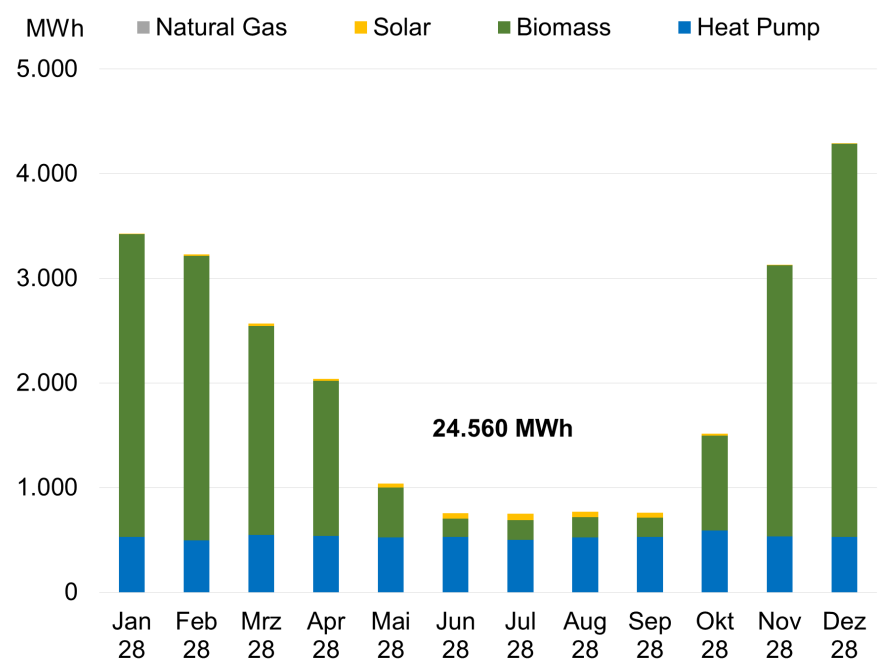

City of Gleisdorf as selected model-region within Austria's real-world laboratory WEIZplus

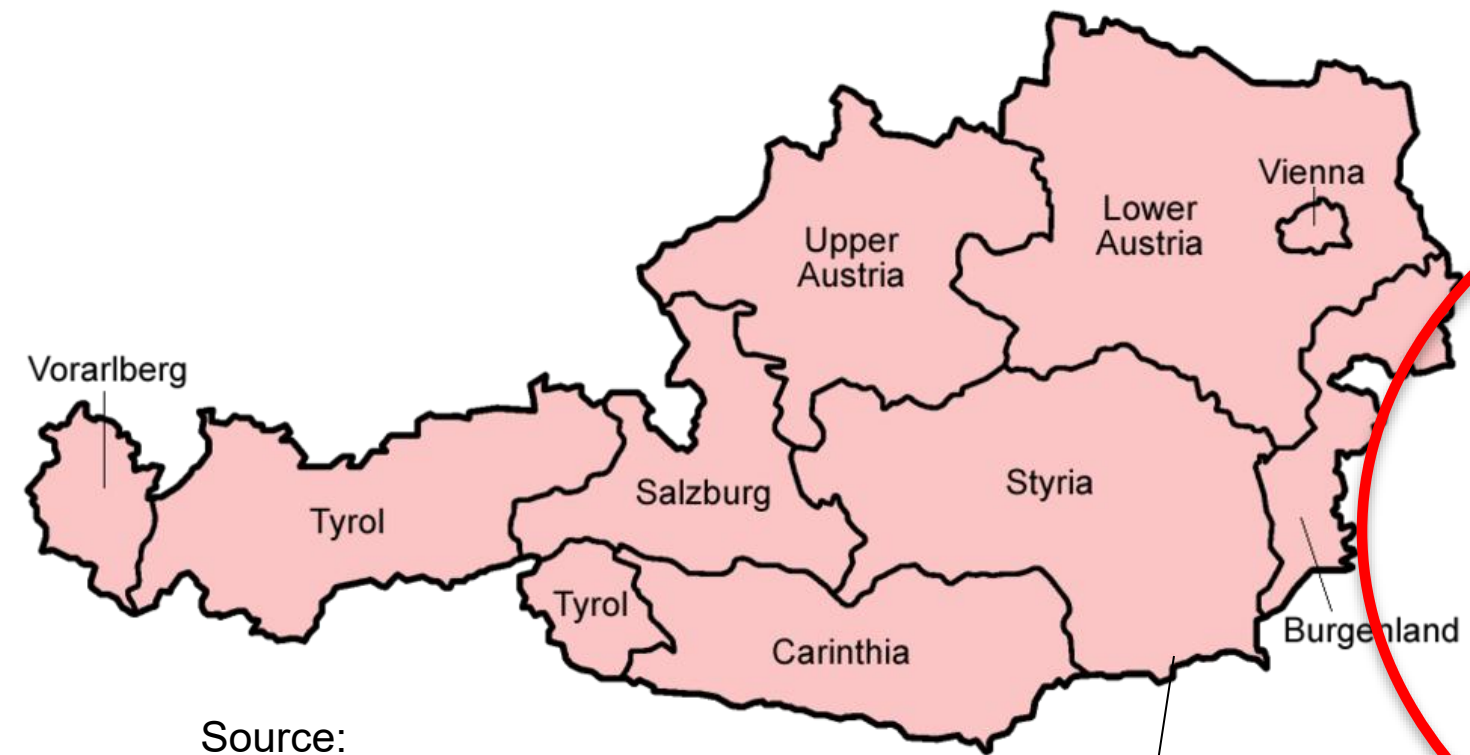

Source: <https://bundesland24.de/bundeslaender/oesterreich/>

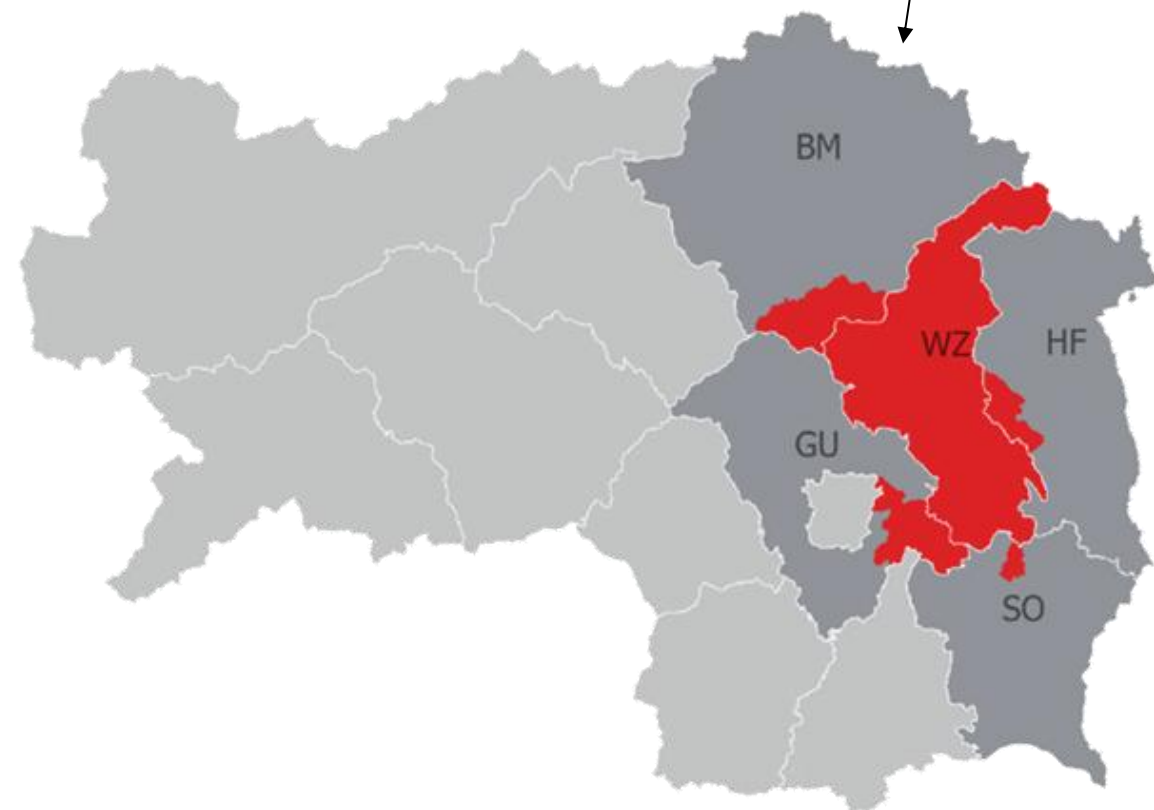

Source: StadtLabor Graz

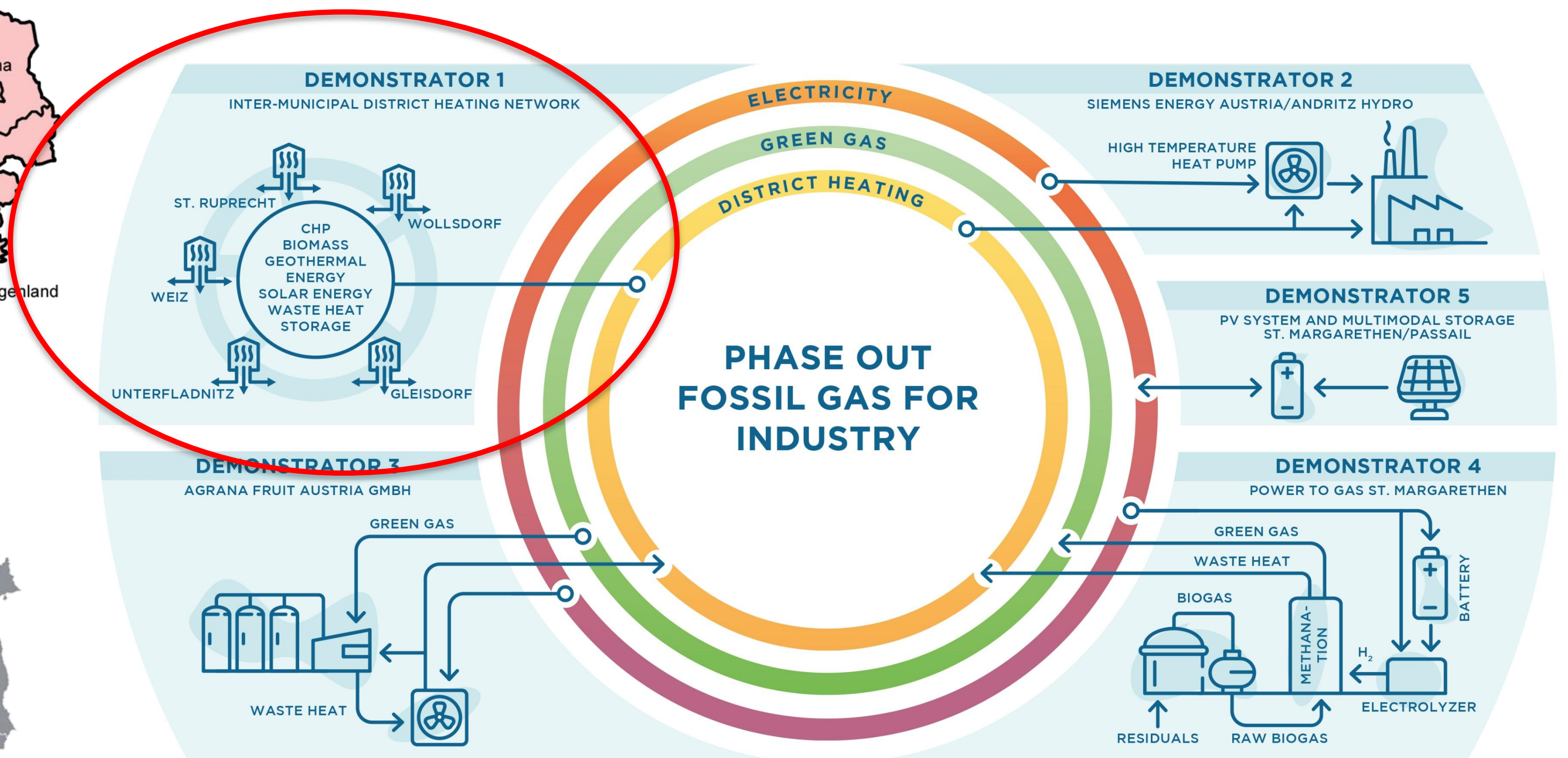

Source: AEE INTEC

Status quo evaluation / data acquisition (2023) – Municipality of Gleisdorf

- 3,528 buildings
- 122 GWh annual heat demand
- Fossil (gas & oil) dominated
→ High potential for fossil phase-out

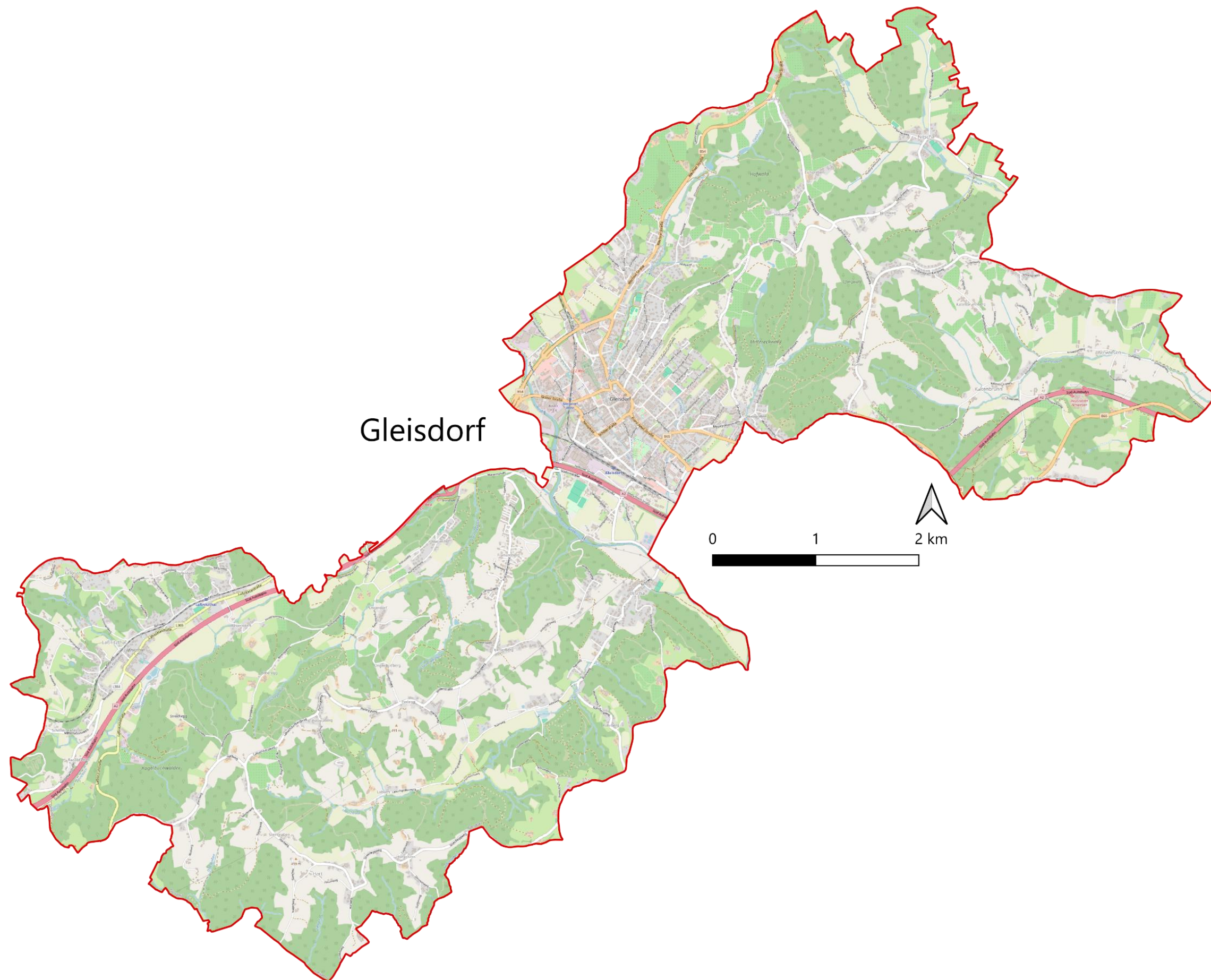

Source: AEE INTEC

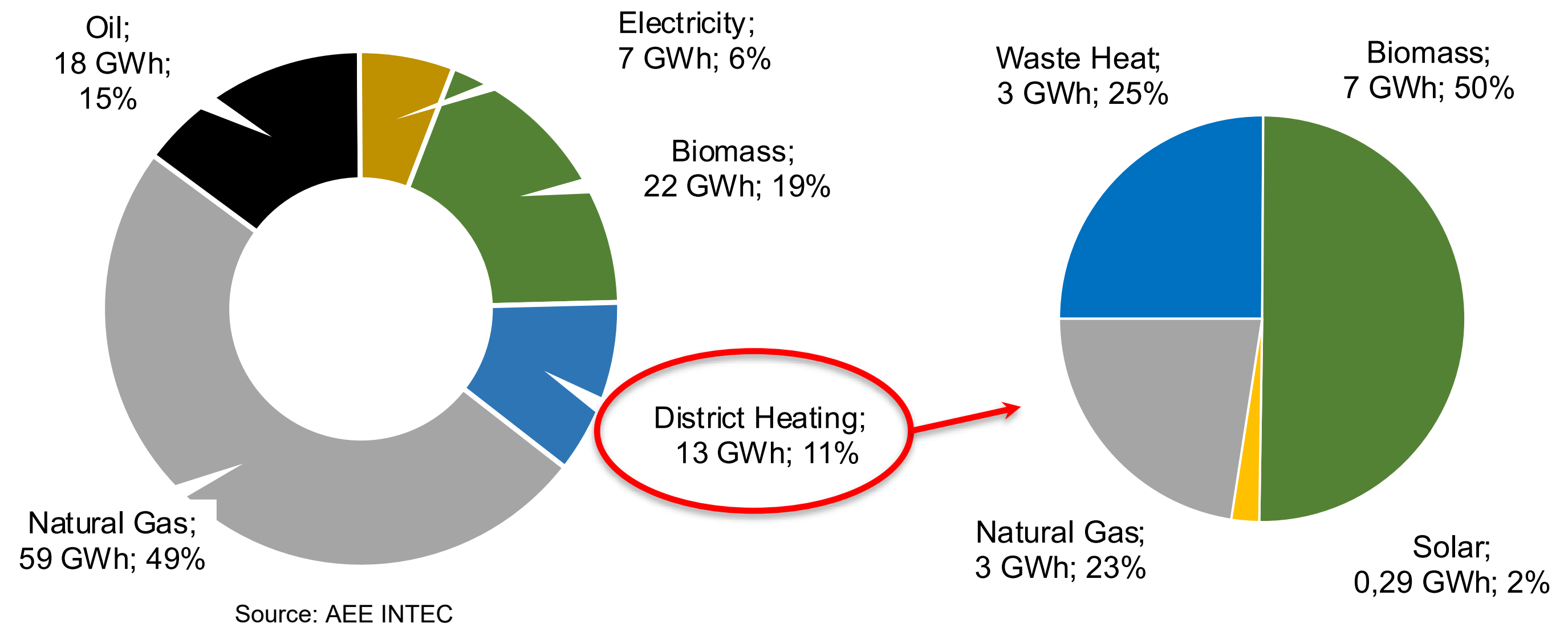

Status quo evaluation / data acquisition (2023) – District heating and model development

- Existing district heating utility
 - 190 Customers; 14km network
 - 13 GWh heat generation
- High expansion/densification potential in the city centre

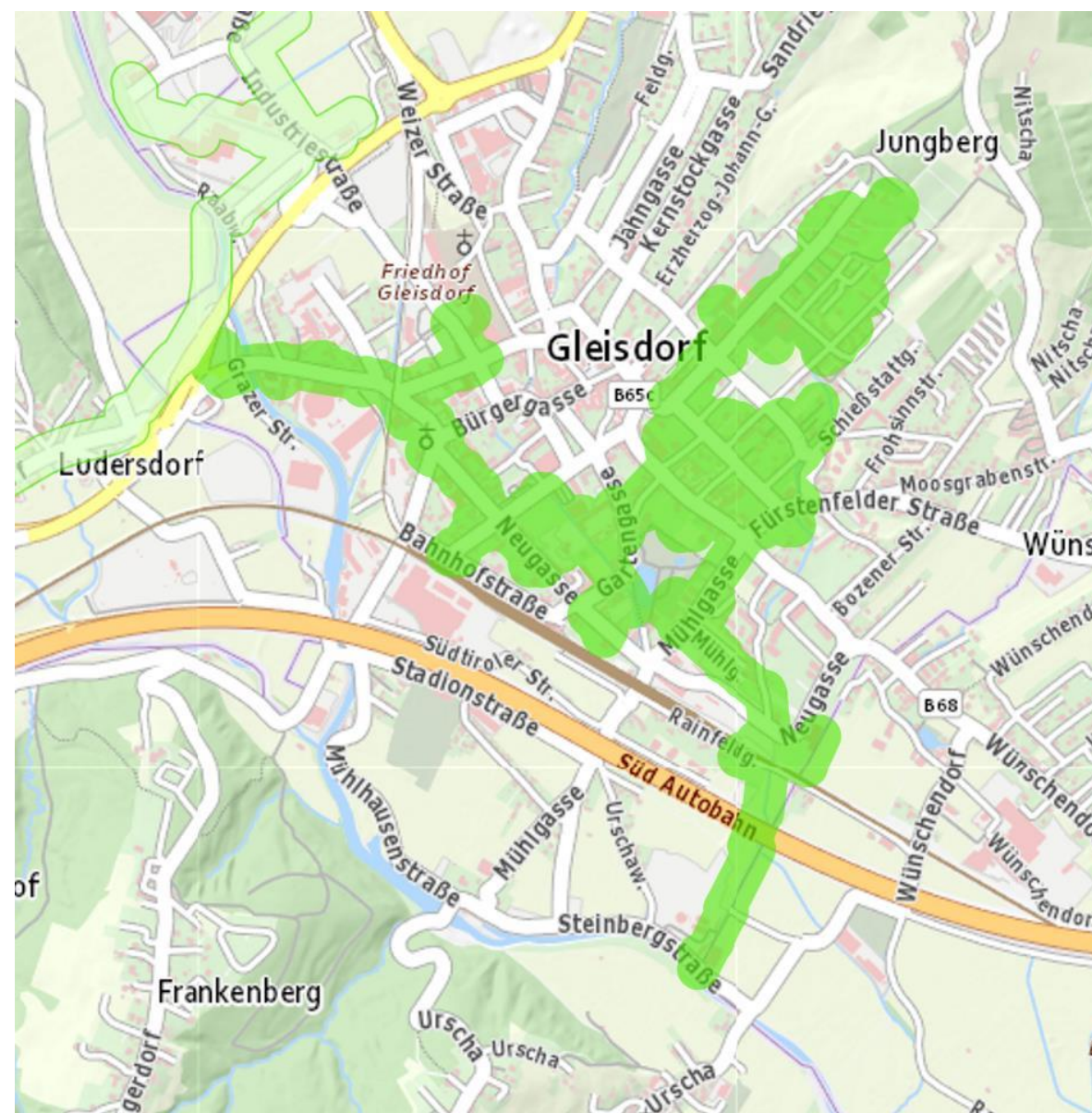

Source: AEE INTEC

District heating network-heat generation 2023

■ Natural Gas ■ Solar ■ Biomass ■ Waste Heat

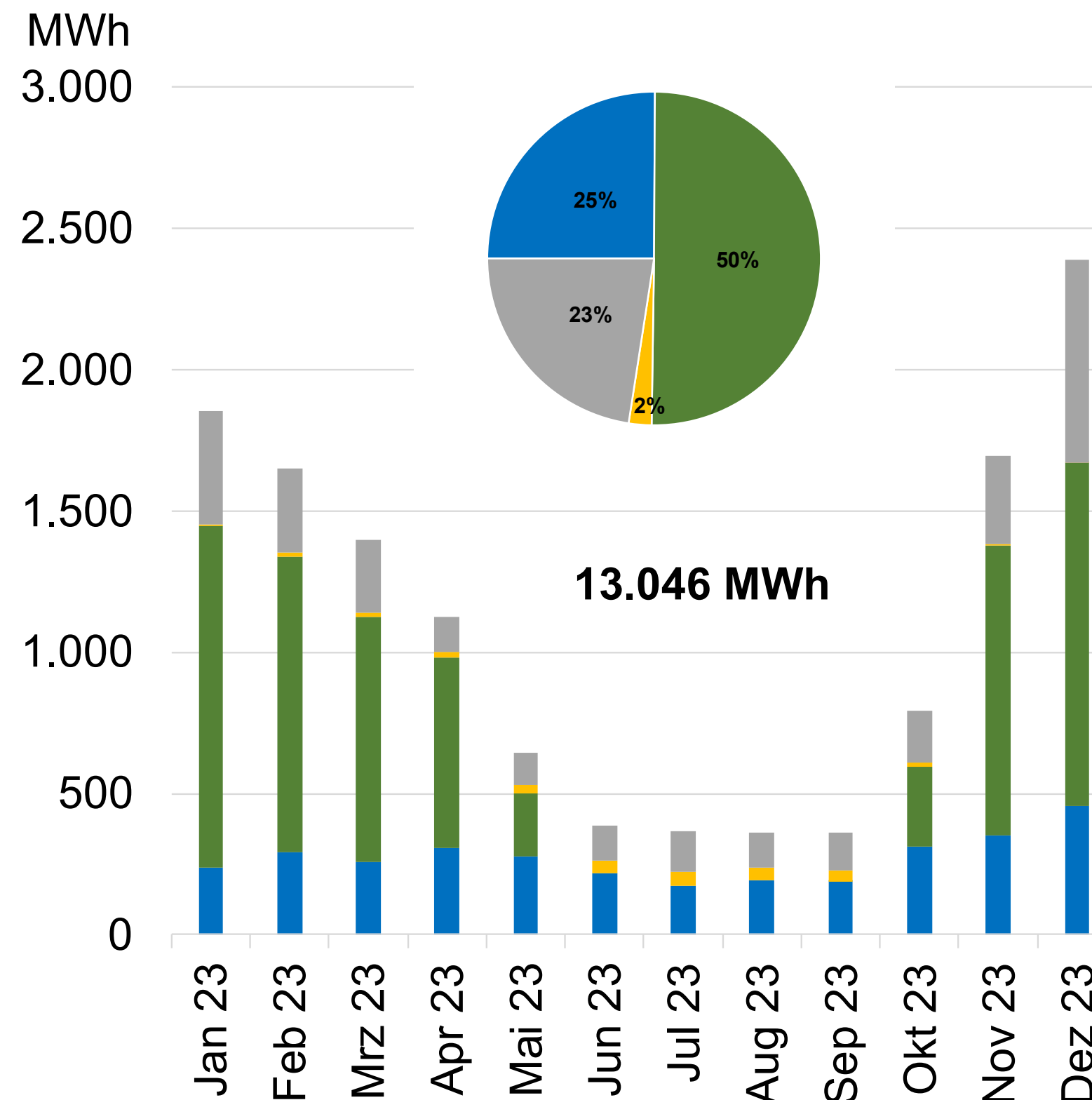

Source: AEE INTEC

Model development using energyPRO dispatch model

- Full year simulation, hourly resolution
- Validated with monitoring data (~1% deviation)

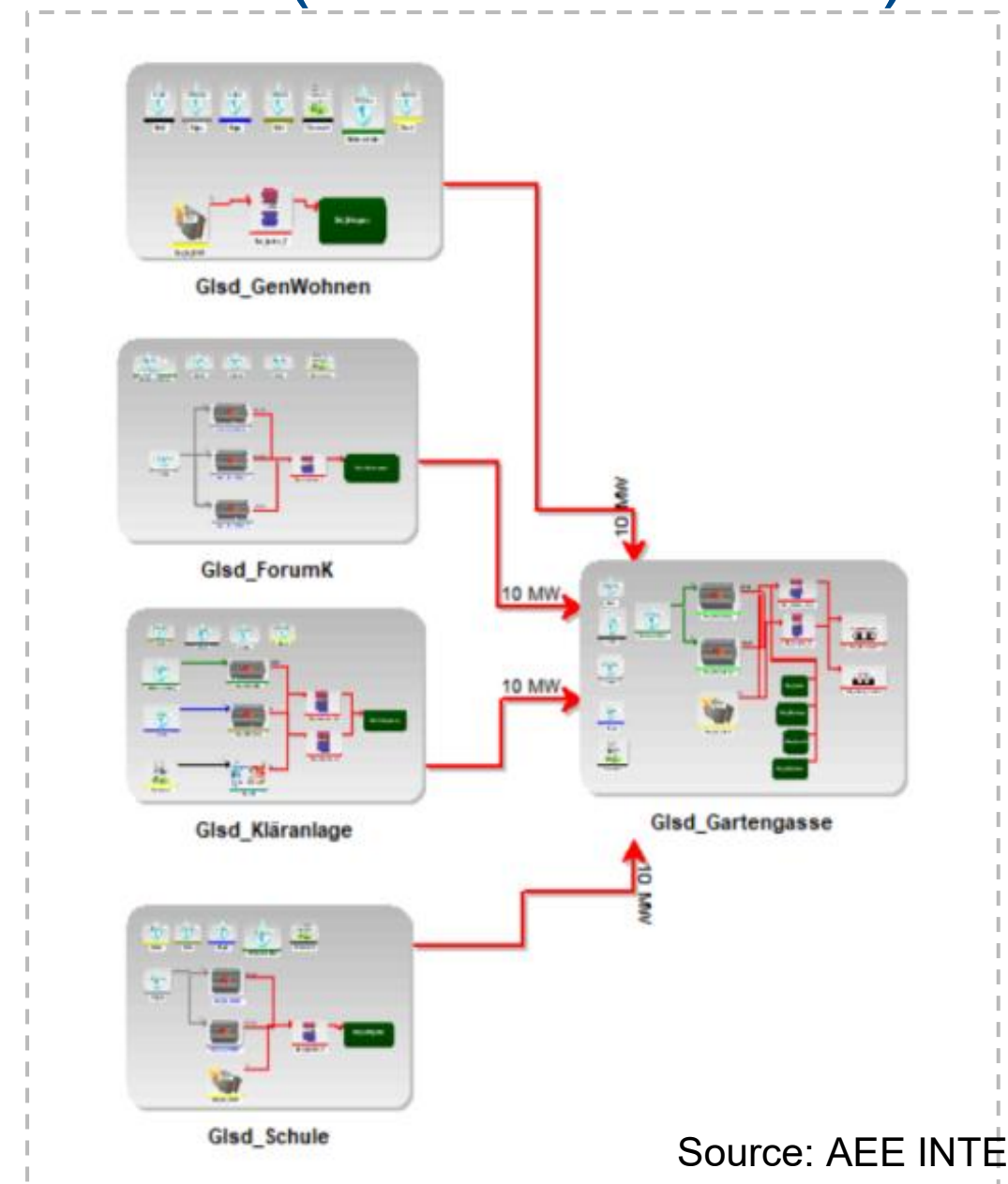

Source: AEE INTEC

GIS based analysis - Areas of Interest (AOI)

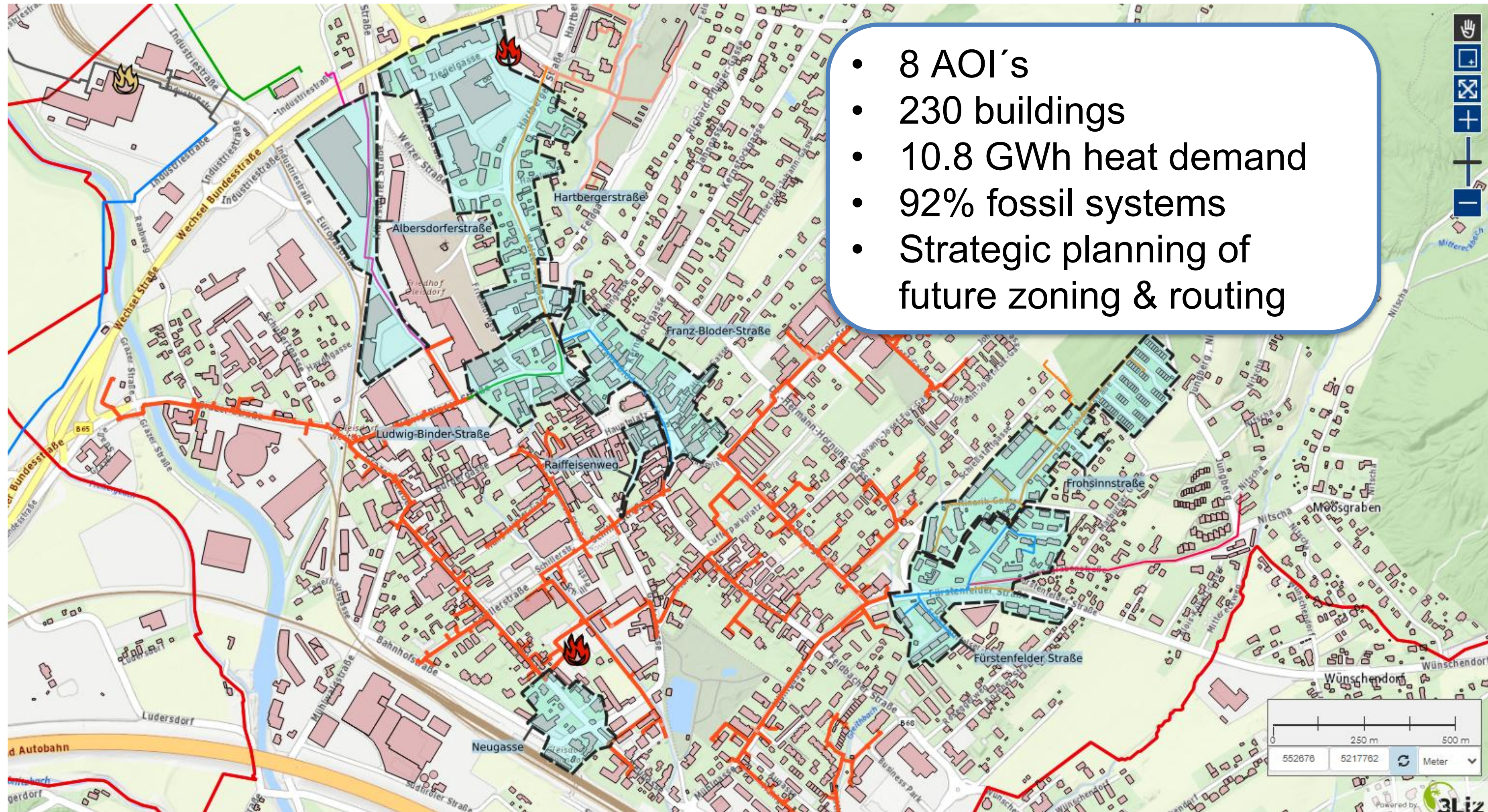

Source: AEE INTEC

Scenario design for the fossil phase-out and energy modelling by simulation including validation

- **Scenario 1: Full connection of all AOs**
- **Scenario 2: Partial connection (90 % fossil systems replaced)**
- **Model extension: 4 MW biomass boiler & storage**

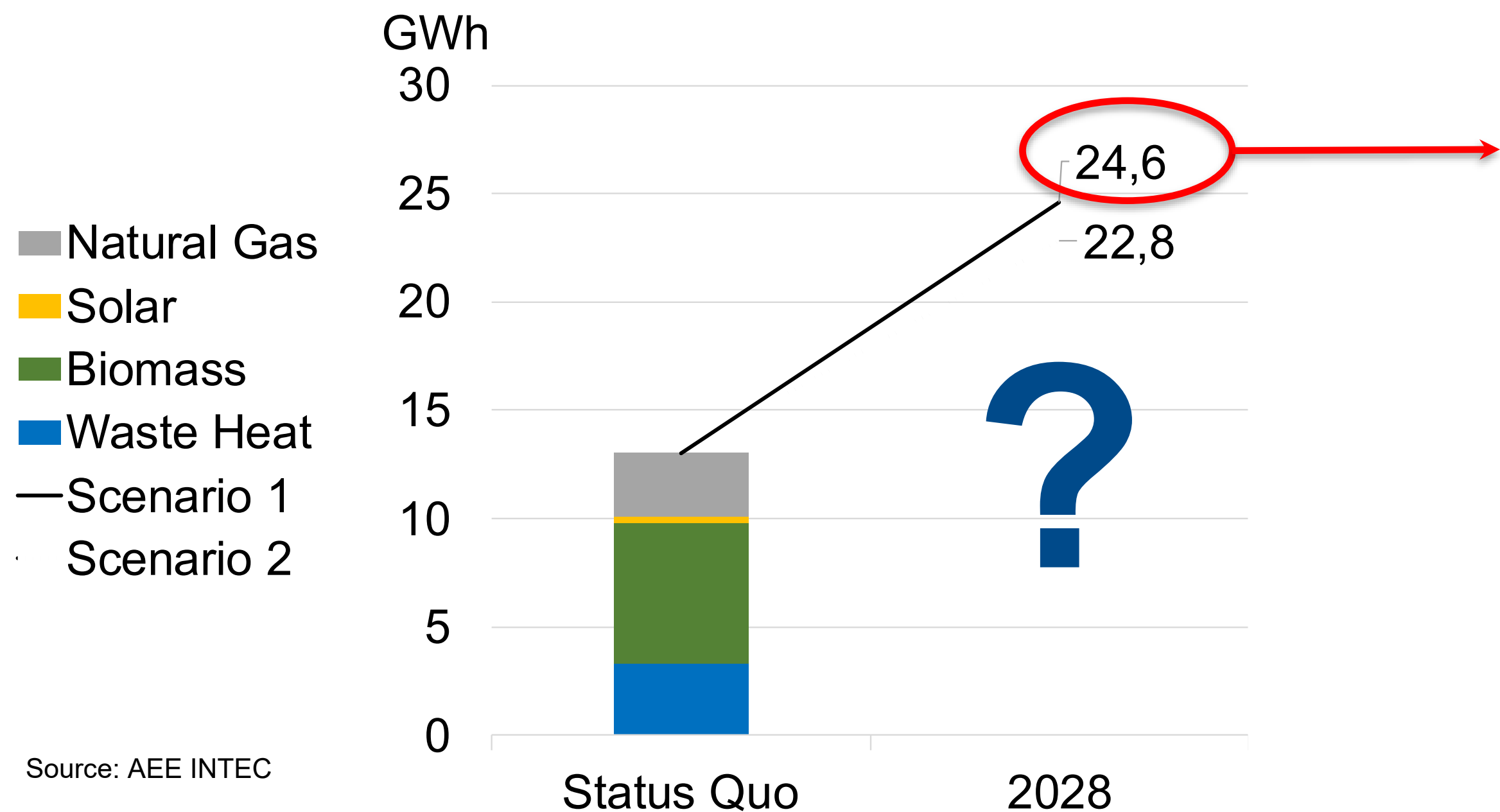

District heating network-heat generation 2028 scenario 1

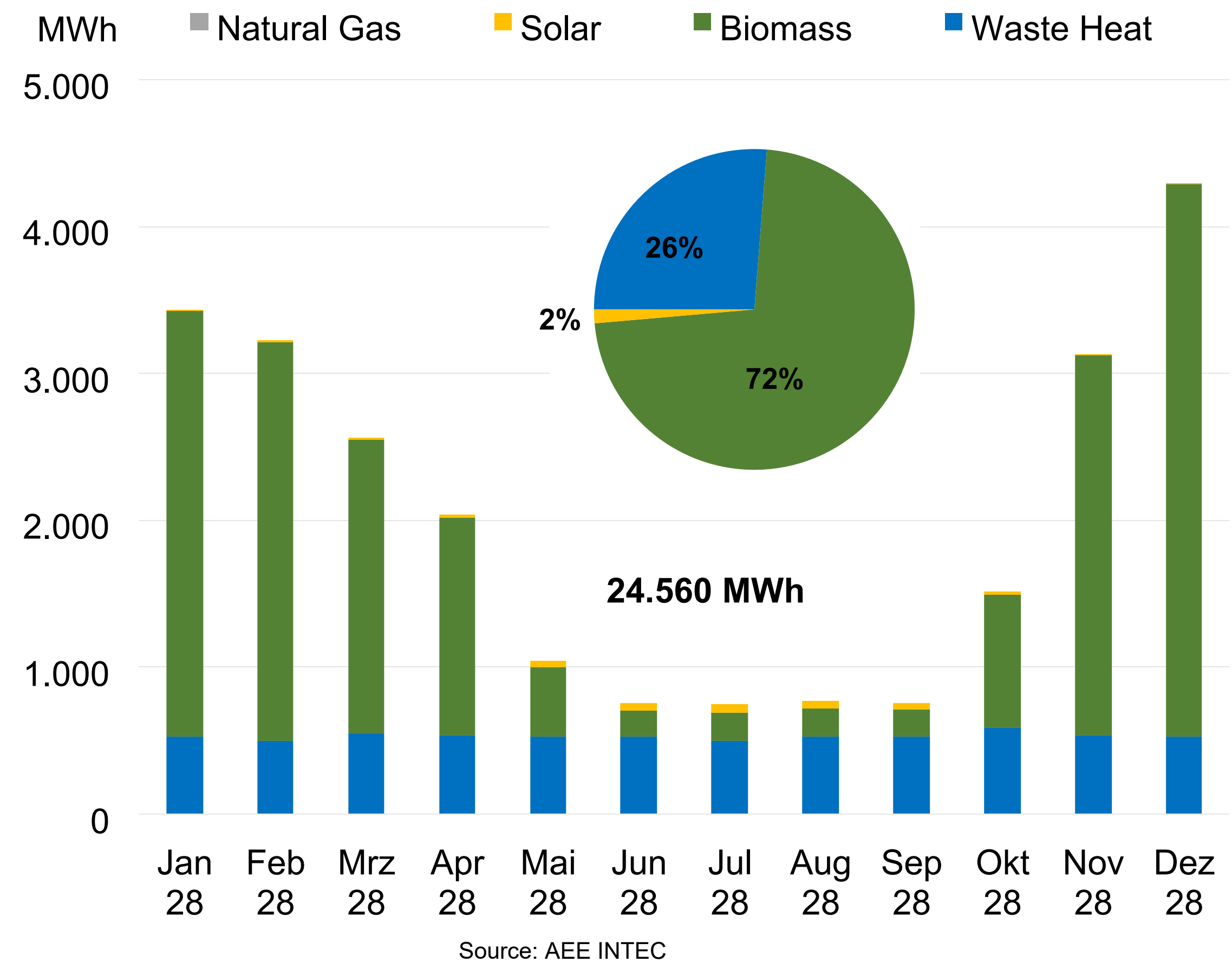

Overall evaluation - total energy generation and specific greenhouse gas emissions

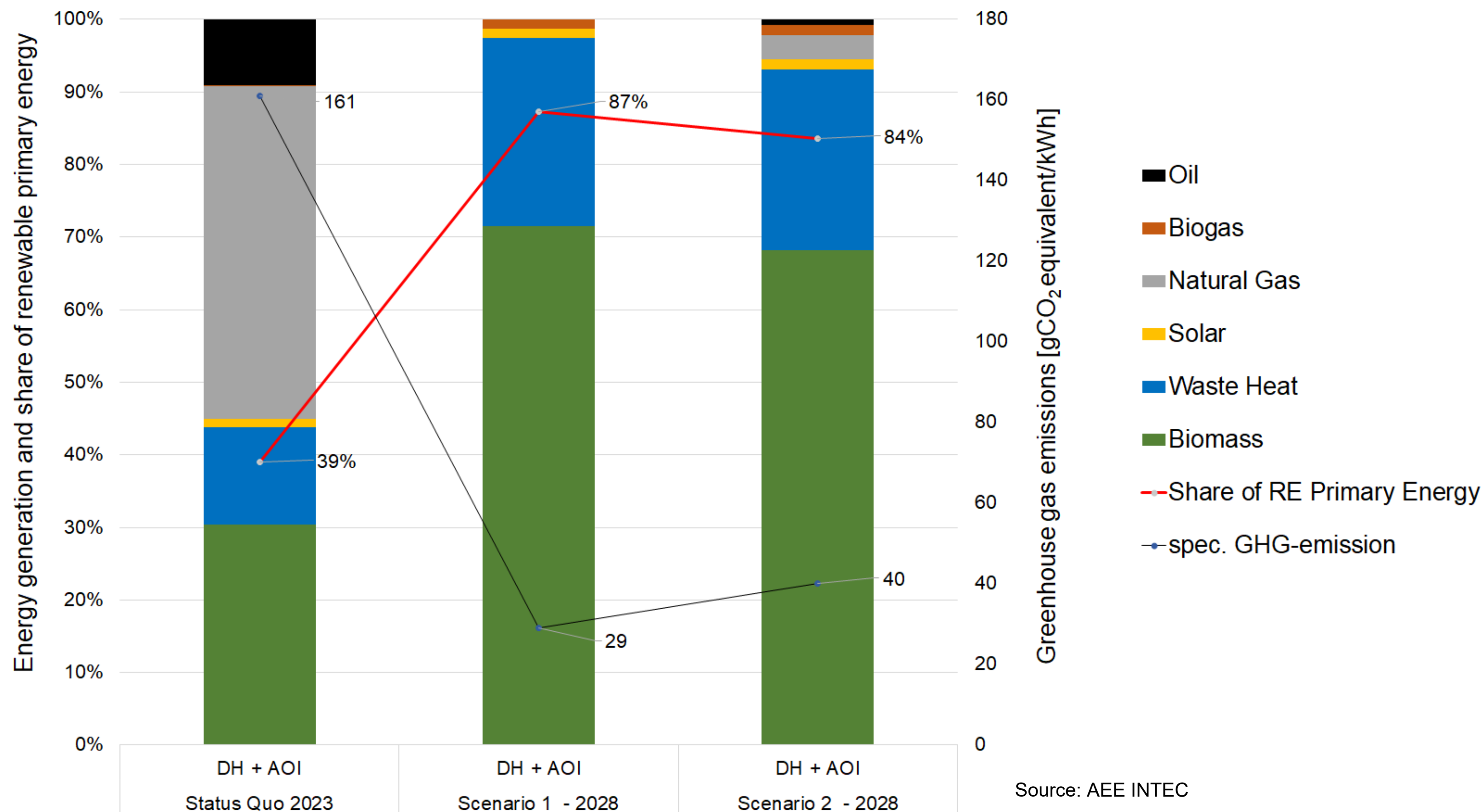

Source: AEE INTEC

- Energy from biomass more than doubled (7.4 to 17.4/16.9 GWh)
- GHG emissions reduction up to 82% (from 161 to 29/40 g/CO₂äquiv/kWh)
- Renewable primary energy share increased enormously (from 39% to 87/84%)

Summary and conclusion

- Replicable, data-driven framework for heat planning developed
- Validated workflow integrating geospatial data management, energy modelling and governance processes
- Practical guideline including lessons learned for replication in other regions available (in German)

„A proven blueprint – ready for the next district heating network and/or municipality!“



Source: AEE INTEC / Canva

Source: AI generated / AEE INTEC





EUBCE 2026
34th European Biomass Conference & Exhibition

AEE INTEC

IDEA TO ACTION

Strategic Planning and Simulation of Biomass Integration into District Heating Networks

An Integrated Approach for the Fossil Phase Out in Gleisdorf, Austria

AEE – Institute for Sustainable Technologies (AEE INTEC)
8200 Gleisdorf, Feldgasse 19, Österreich

Website: www.aee-intec.at
Twitter: @AEE_INTEC



Klima- und Energie-
Modellregionen
Wir gestalten die Energiewende



Funded by
Federal Ministry
Innovation, Mobility
and Infrastructure
Republic of Austria



Contact:
Joachim Kelz
j.kelz@aee.at
0043 3112 5886 236