

ISEC

INTERNATIONAL
SUSTAINABLE ENERGY
CONFERENCE 2018

3. - 5. Oktober 2018
Congress Graz
Österreich

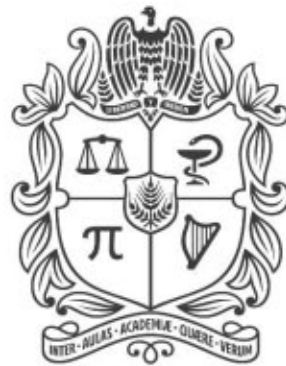

UNIVERSIDAD
NACIONAL
DE COLOMBIA

Proyecto cultural y colectivo de nación

Sede Medellín

TECHNICAL AND POTENTIAL ANALYSIS OF THERMAL COOLING DISTRICTS IN COLOMBIA

M.Sc. Carlos Mario Ceballos Marín
Ph.D. Candidate

Graz, Austria
2018



Location of Colombia

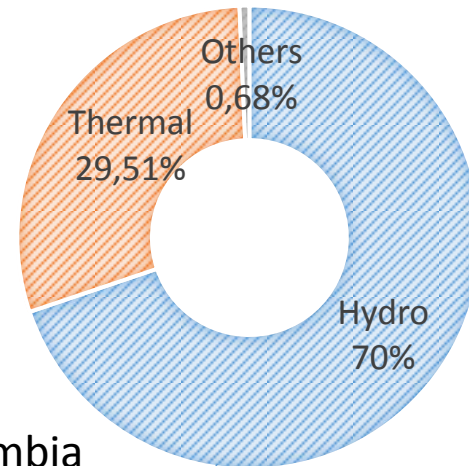

Data taken from XM

Energy balance of Colombia (primary resource)

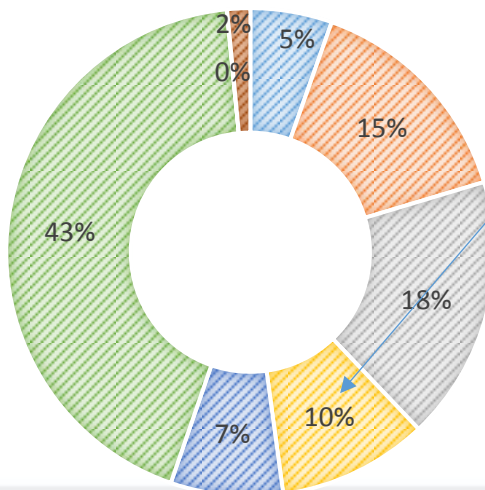

Data taken from UPME, 2018

■ Bagasse ■ Coal ■ Natural gas ■ Hydro ■ Wood ■ Crude Oil ■ Residues ■ Renewables



Energy consumption by sector

Data taken from UPME, 2016

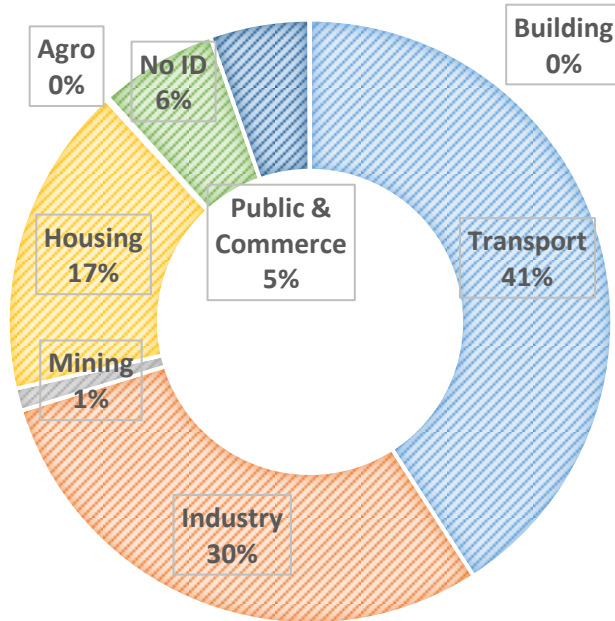

Demand considerations:

Cities > 200.000 inhabitants

Average annual temp > 20° C (68 °F)

Industry and Public & Commercial sectors are the ones where the highest consumption of cold is observed

Selected cities

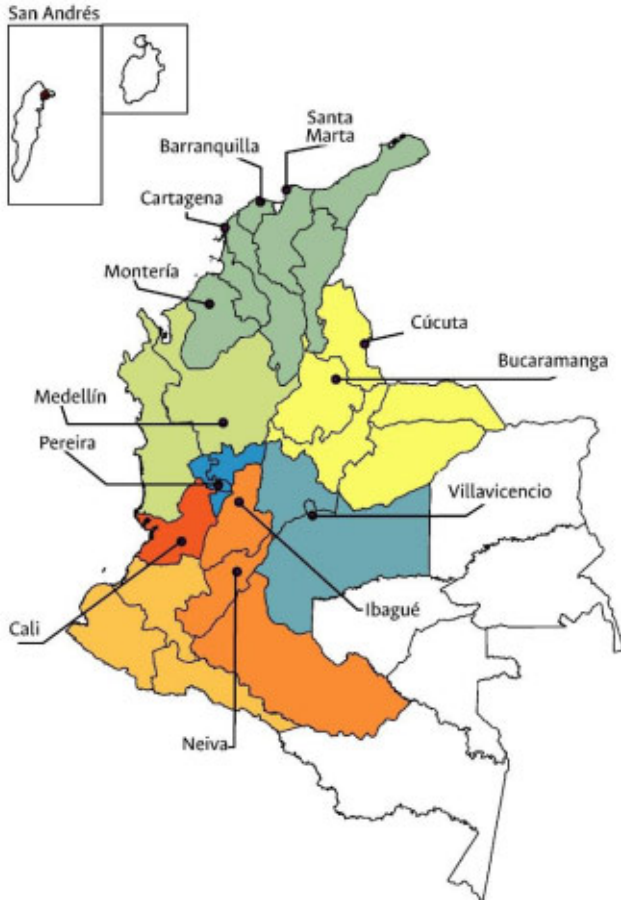

Sede Medellín



Industry

- Commercial parks and free trade zones
- Administrative areas (offices)



Public Buildings

- Government offices



Hotels and Convention centres

- Rooms and common covered areas
- Lobbies, corridors and restaurants
- Places used for events, congresses, conferences or meetings



Educational Buildings

- Schools and Universities
- Classrooms and administrative offices



Hospitals

- Hospitals and clinics (number of offices)
- Operating rooms, intensive care units (ICU), corridors, and common indoor areas



Urban equipment

- Sport centres (Stadiums and sport units)
- Airports and bus terminals

P_{Total} : total energy that must be supplied to a space per unit of time [BTU/h].

$$P_{Total} = P_{(T)} \times A + C$$

$P_{(T)}$: cooling power that must be supplied to a space per unit of area and time [BTU/hm^2].

A : area to be cooled in [m^2]

C : [BTU/h] is the thermal load. Additional power that must be supplied to the space to be cooled due to the presence of people or objects in it.

Table 1. Cooling power per unit area and time in each temperature range

Climate	Min (°C)	Max (°C)	BTU/hm ²
Cold	-	18	500
Warm	19	25	550
Hot	26	33	600
Very hot	34	-	650

Table 2. Thermal load [BTU / h] associated with different objects in the spaces to be cooled

Object	BTU/h
Person	500
Computer	400
Conventional TV	600
Halogen bulb	400
Flat TV	400

Summary by sectors of the cooling demand (in thousands of RT) by city

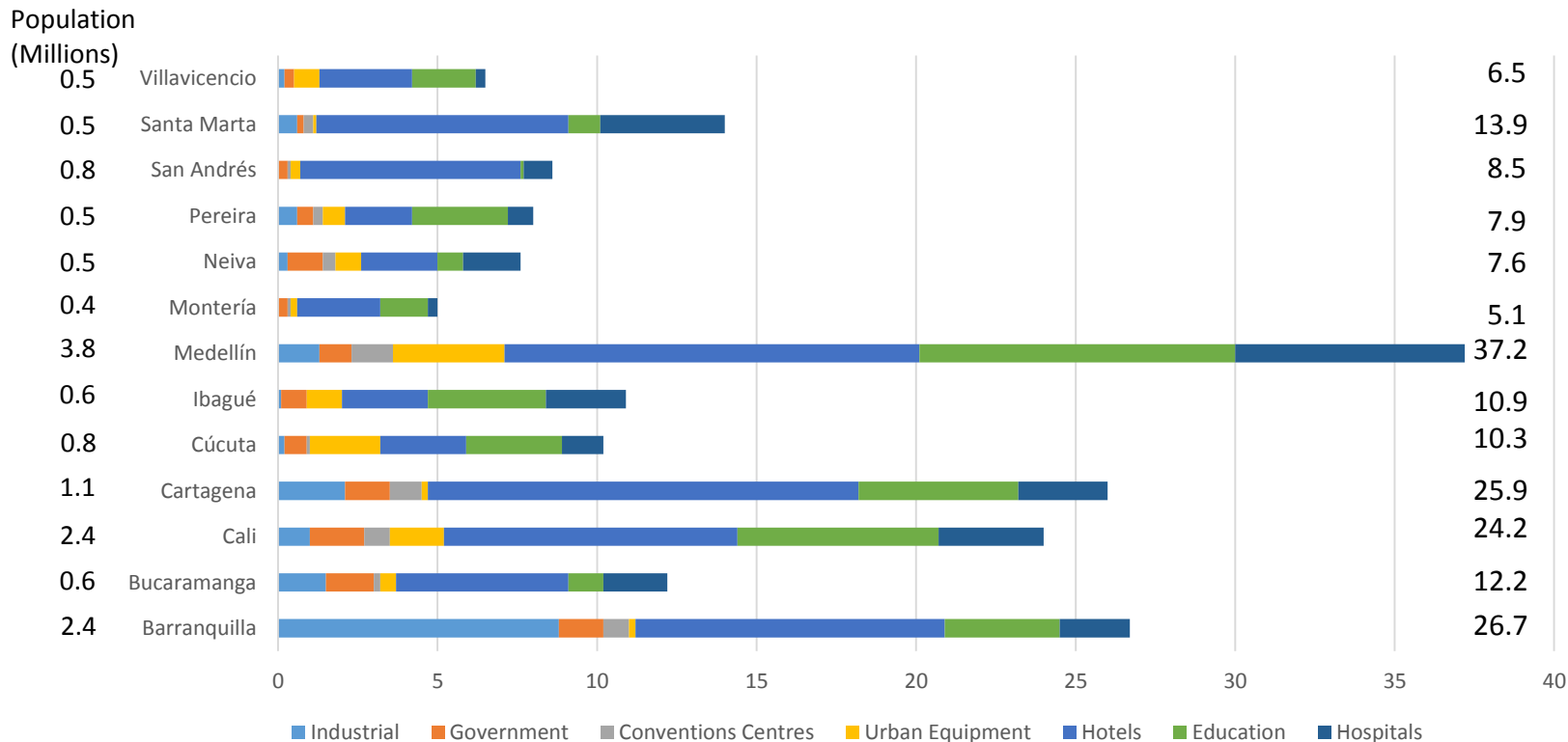

Assumptions considered:

- Hotels: 35 m² of area per room plus 20% related to the common areas of the hotel (corridors and lobby), plus a thermal load per room of 3 people, 3 bulbs, 0.5 computers, and 1.5 TVs.
- Hospitals: areas of 25 m² by room, 37 m² by operating room, and 15 m² by ICU were used.
- Industrial parks: only 10% of the total area of the industrial parks or free trade zones are considered for cooling.
- Building plans, offered rooms, news, and others were used to estimate the areas and the required cold power.

Cooling technologies

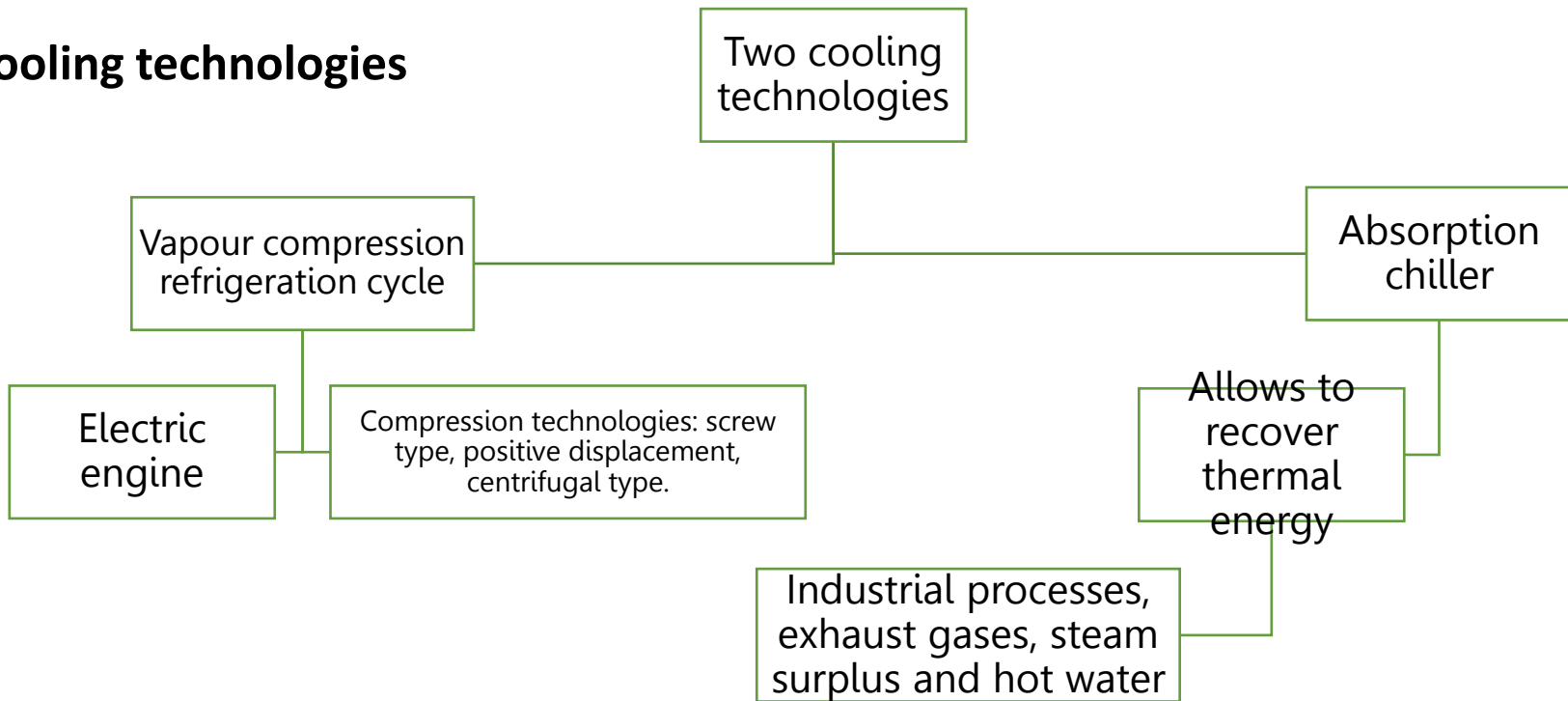

Cooling district packages

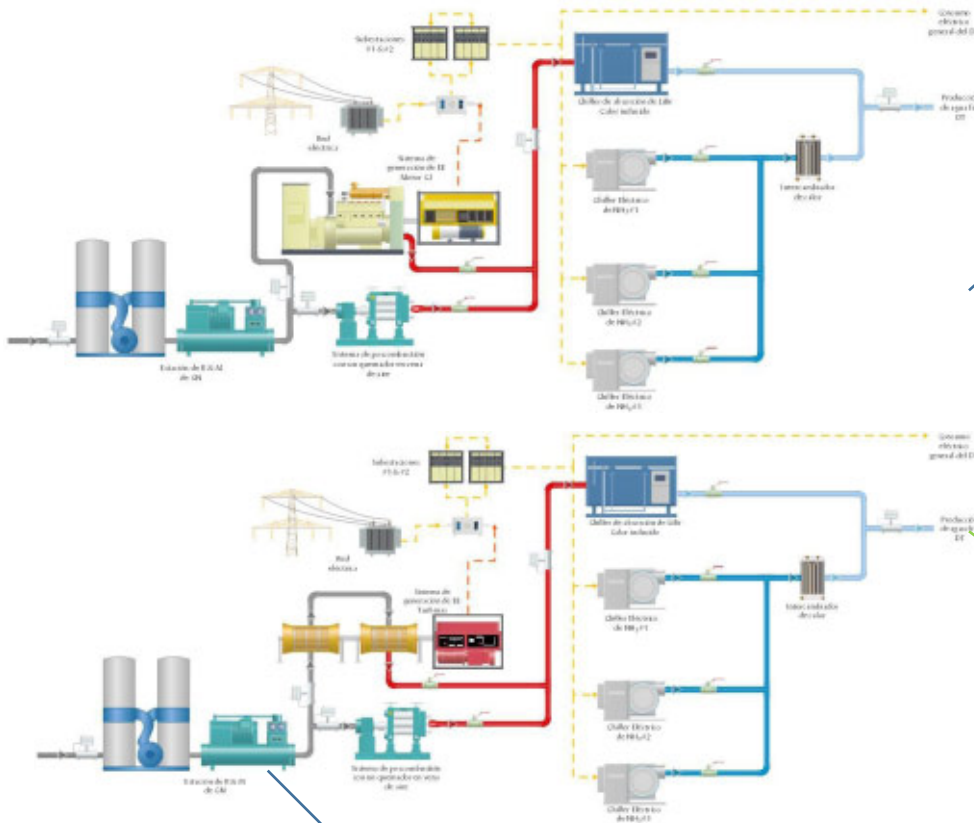

1,200 RT (package 1)

SDMO GXC1200 (MTU Engine)
2 units of *Carrier* electric
compressor Chiller
(Acquaforce)

6,800 RT (package 2)

Taurus T60 Solar turbine
8 units of *Carrier* electric
compressor Chiller
(Acquaforce)

Sede Medellín

Conventional refrigeration systems
use R11, R22 and HFC 134 as the
refrigerant.
Model for CDs employ R134a



UNIVERSIDAD
NACIONAL
DE COLOMBIA

With LEAP tool

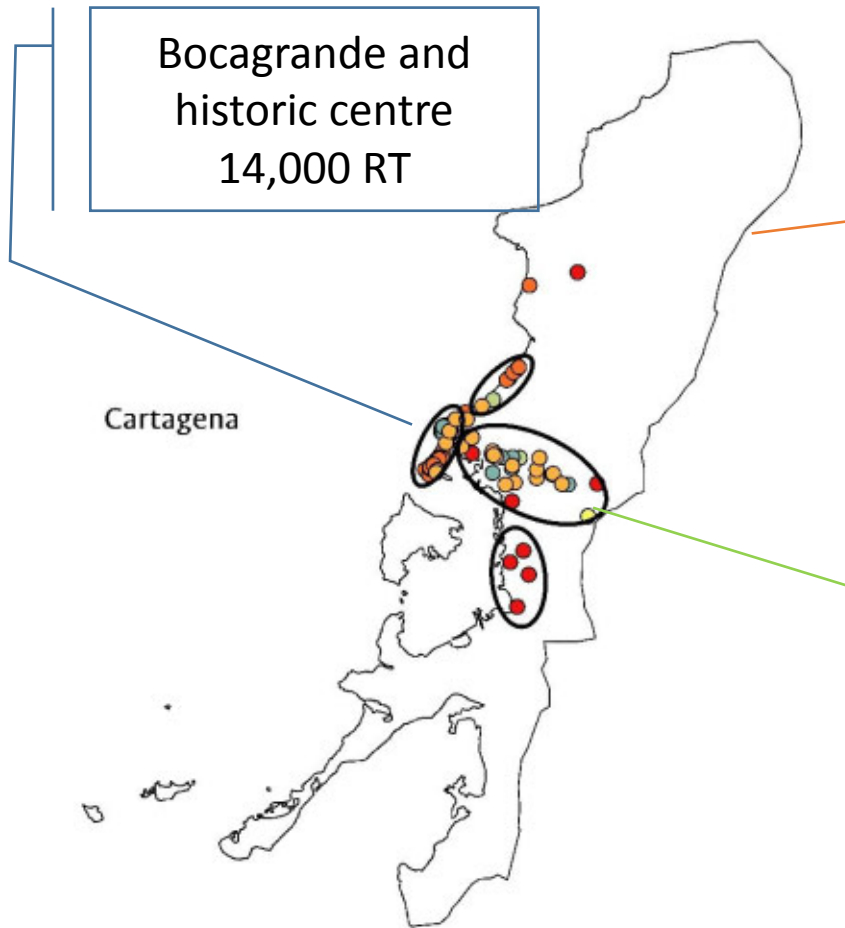

Bocagrande and
historic centre
14,000 RT

Cartagena

Rule:

For a user to be profitable on a CD, he must demand at least 1 RT every 800 m from the CD

Cooling districts aggregated
by geography

- Education
- Urban equipment
- Potencial cooling district (by geography)
- Government
- Industry
- Hospitals
- Hotels
- Convention centres



With LEAP tool

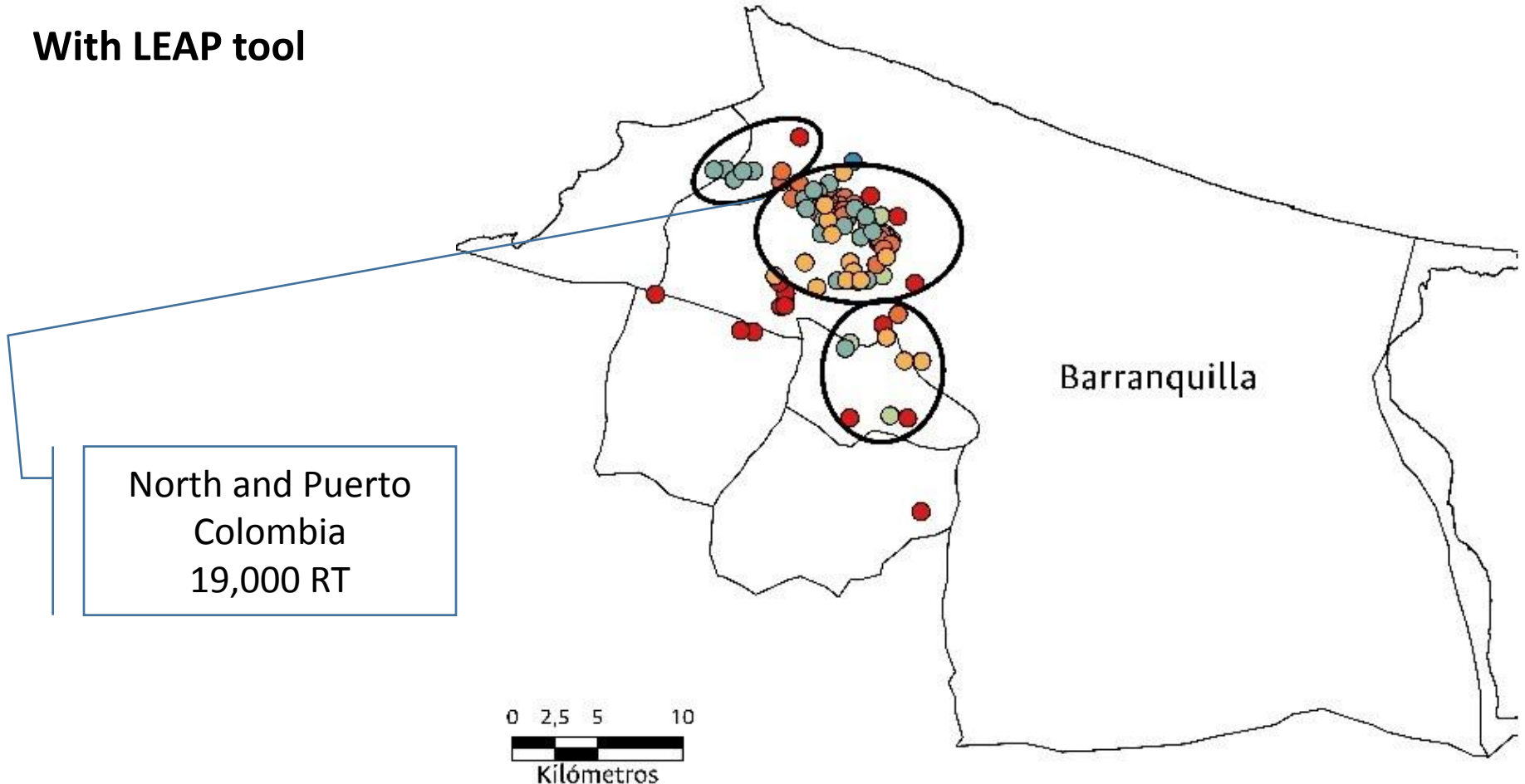

North and Puerto
Colombia
19,000 RT

Barranquilla



- Education
- Urban equipment
- Potential cooling district (by geography)
- Government
- Industry
- Hospitals
- Hotels
- Convention centres

Sede Medellín

With LEAP tool

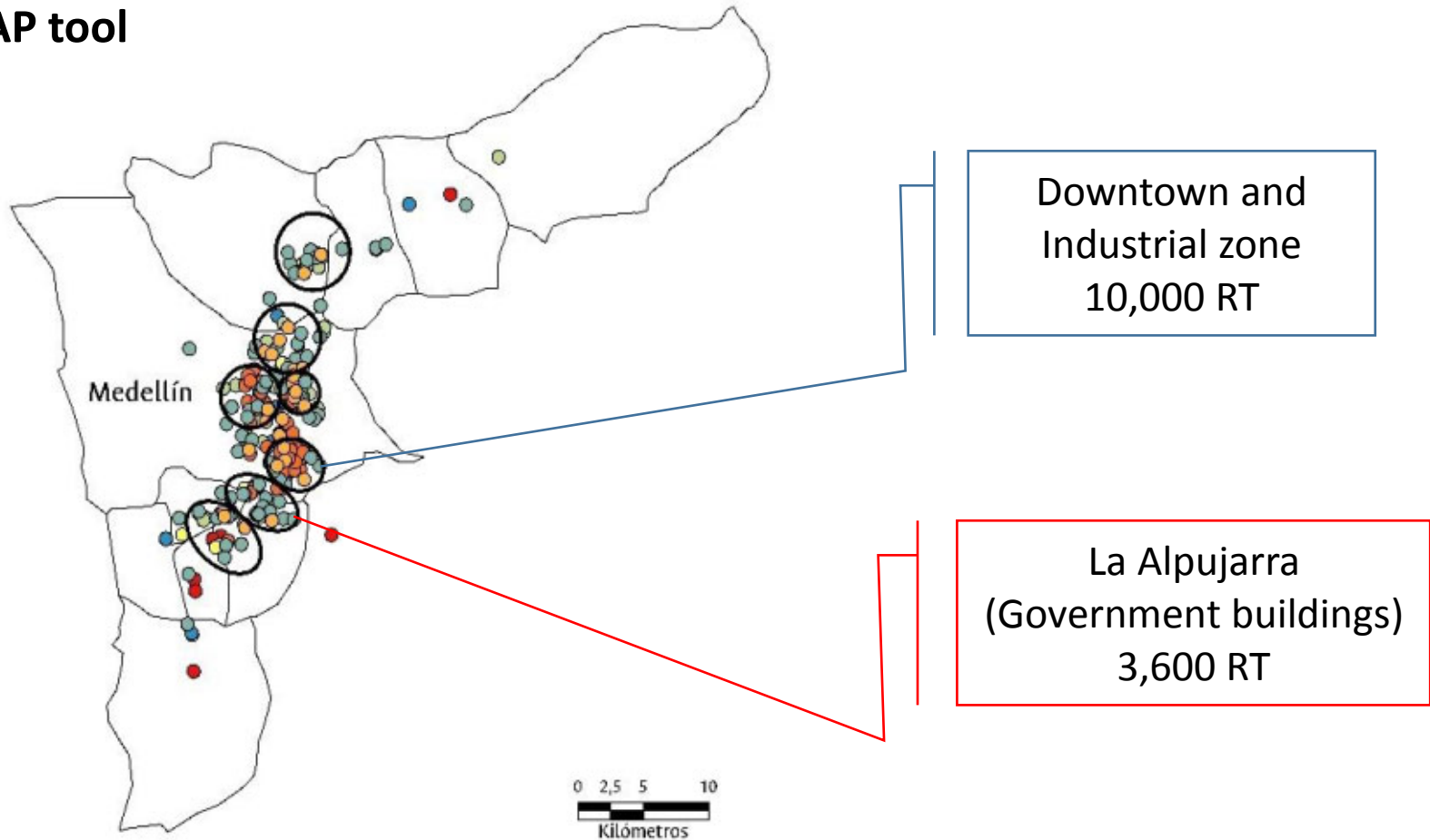

- Education
- Urban equipment
- Potencial cooling district (by geography)
- Government
- Industry
- Hospitals
- Hotels
- Convention centres



With LEAP tool

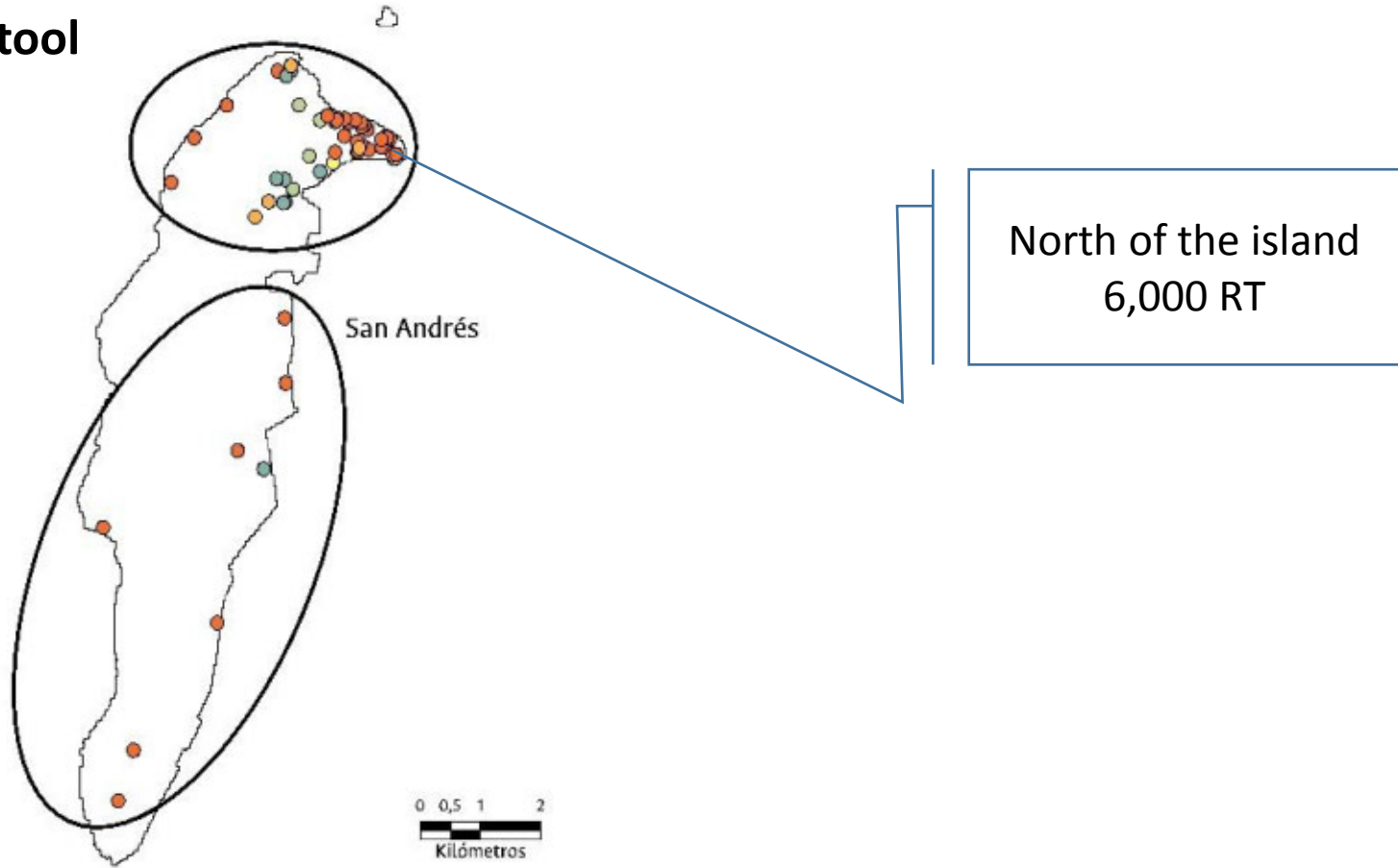

- Education
- Urban equipment
- Potencial cooling district (by geography)
- Government
- Industry
- Hospitals
- Hotels
- Convention centres



Combining local energy resources and technological configurations:

OPTION A. SEA WATER AIR CONDITIONING (SWAC)

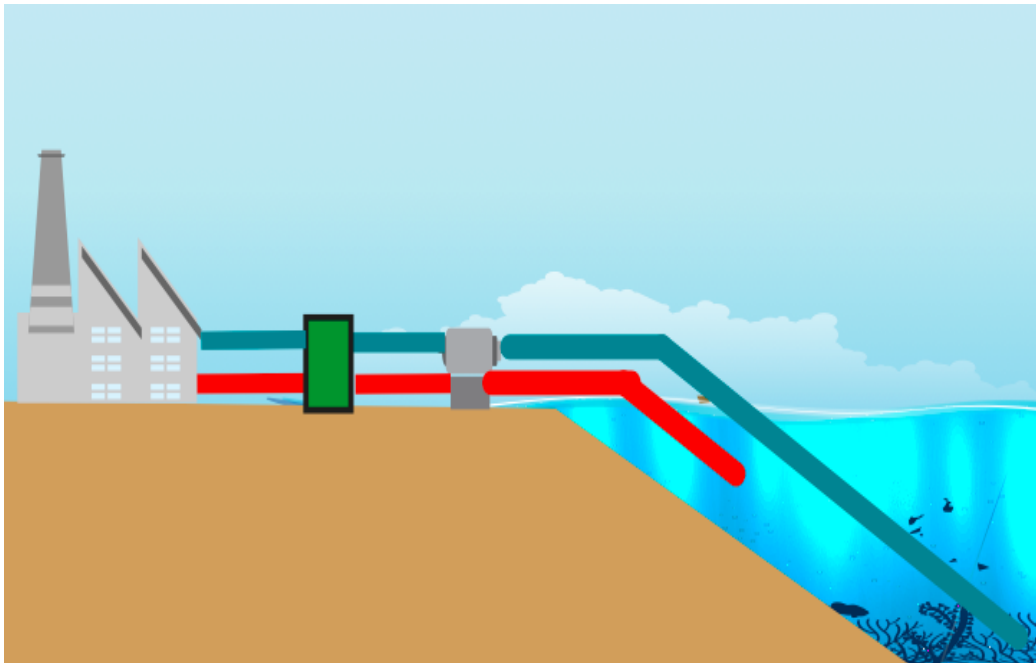

Use of deep ocean seawater directly for air conditioning.

Water located at 80 m deep is approximately at 4 °C.

Pump the deep water and use it as a cooling fluid for the CD.

The water is deposited back to the sea over the surface.

Operating costs of this system are mainly related to water pumping

Combining local energy resources and technological configurations:

OPTION B. COOLING WITH RENEWABLE ENERGIES

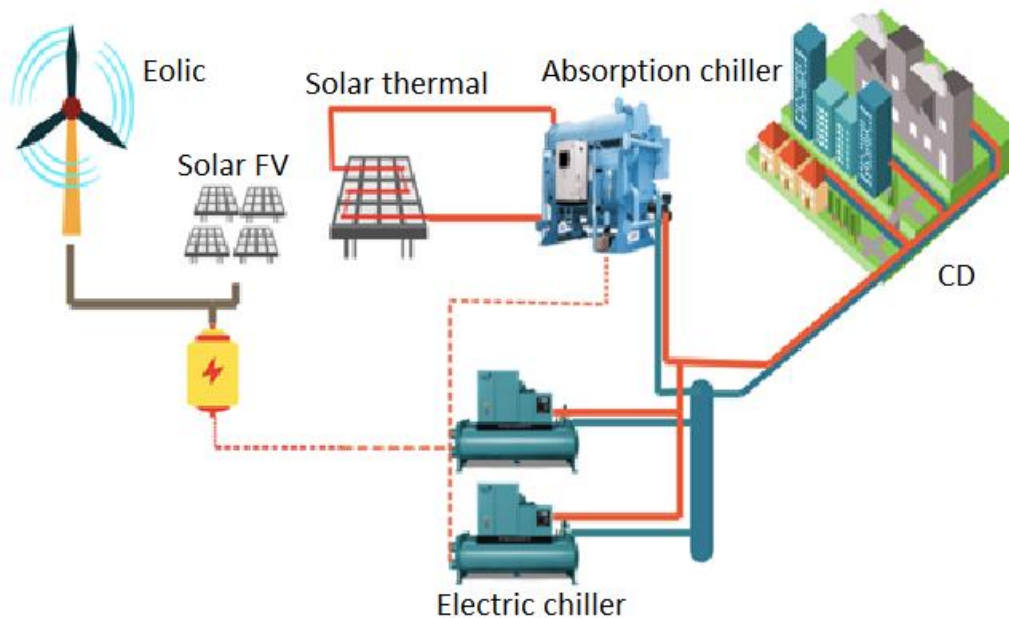

Steam compression chillers and absorption chillers.

Electricity from wind energy and solar PV, and with energy from SIN as the backup

For absorption chillers, the use of hot water from thermal solar energy or hot water coming from industrial processes is proposed.

Combining local energy resources and technological configurations:

OPTION C. NATURAL GAS COGENERATION AND SOLAR THERMAL/PV

OPTION D. NATURAL GAS OR FLARE GAS COGENERATION

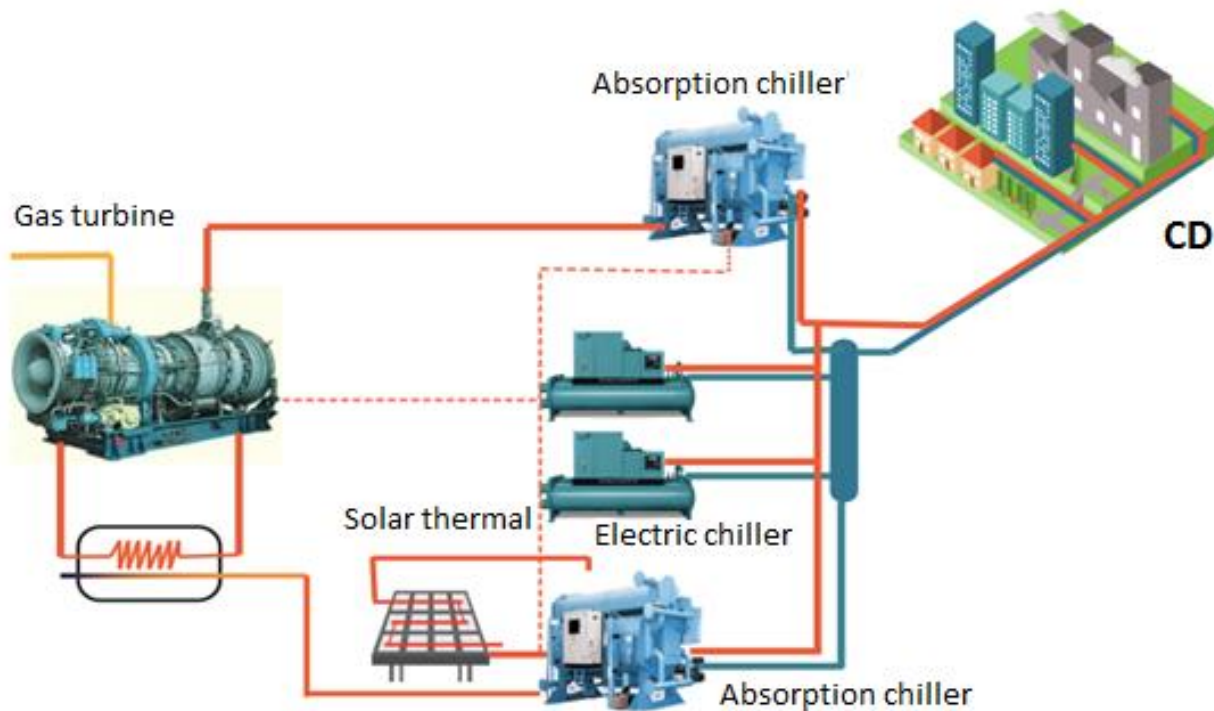

Combining local energy resources and technological configurations:

OPTION E. ELECTRIC CHILLERS (100%)

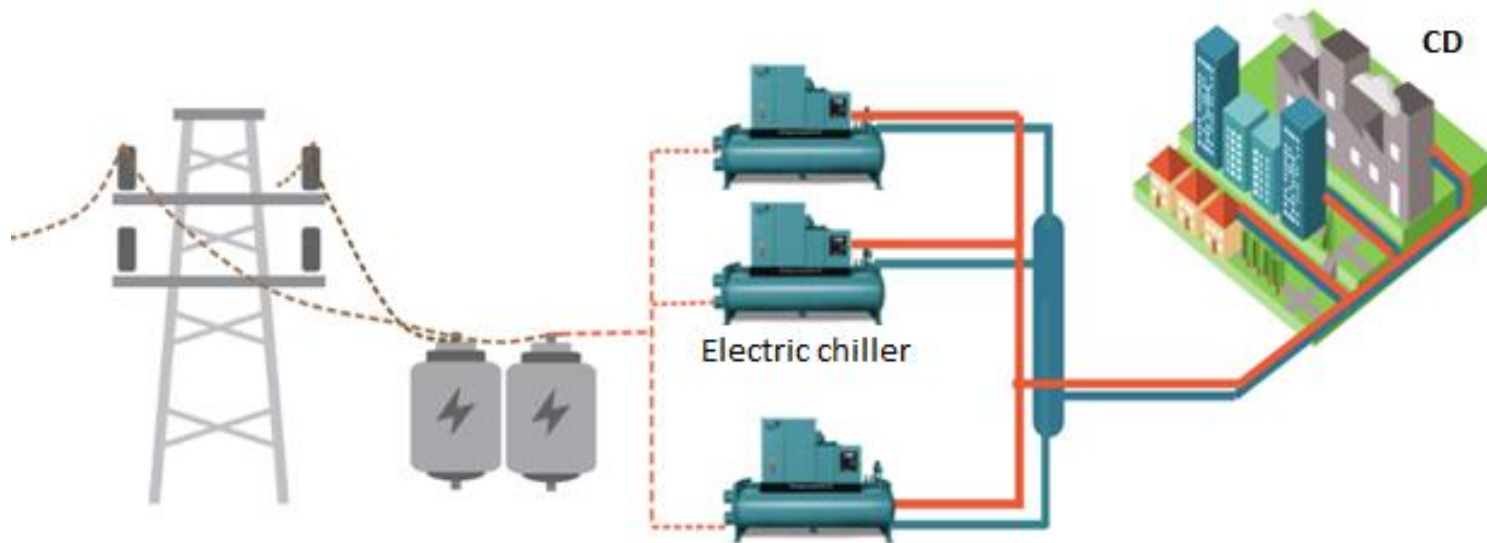

Conventional resources

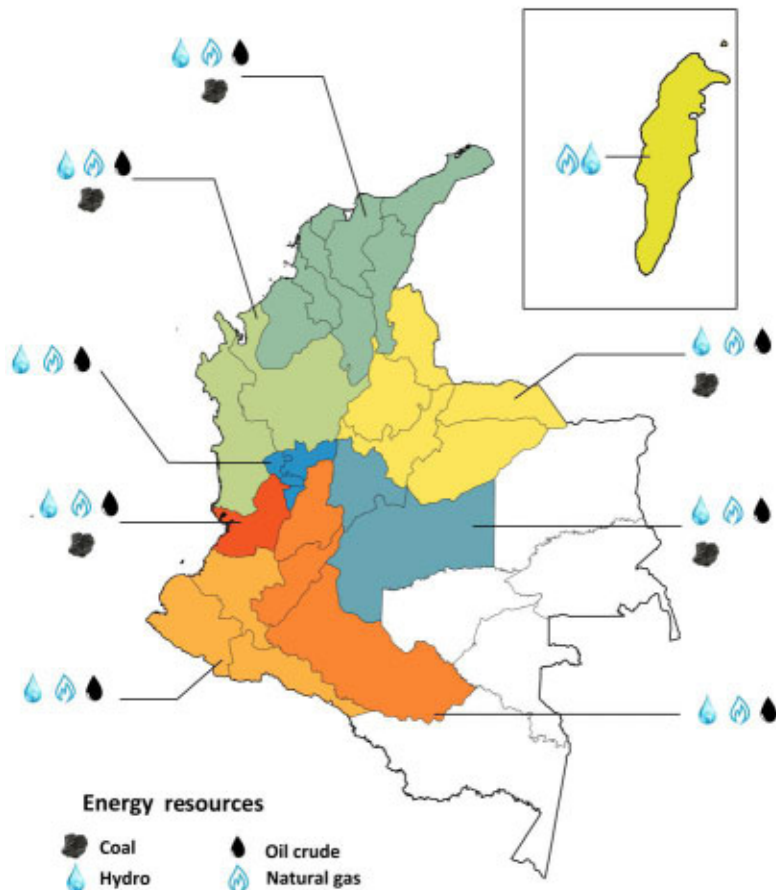

Non-conventional resources

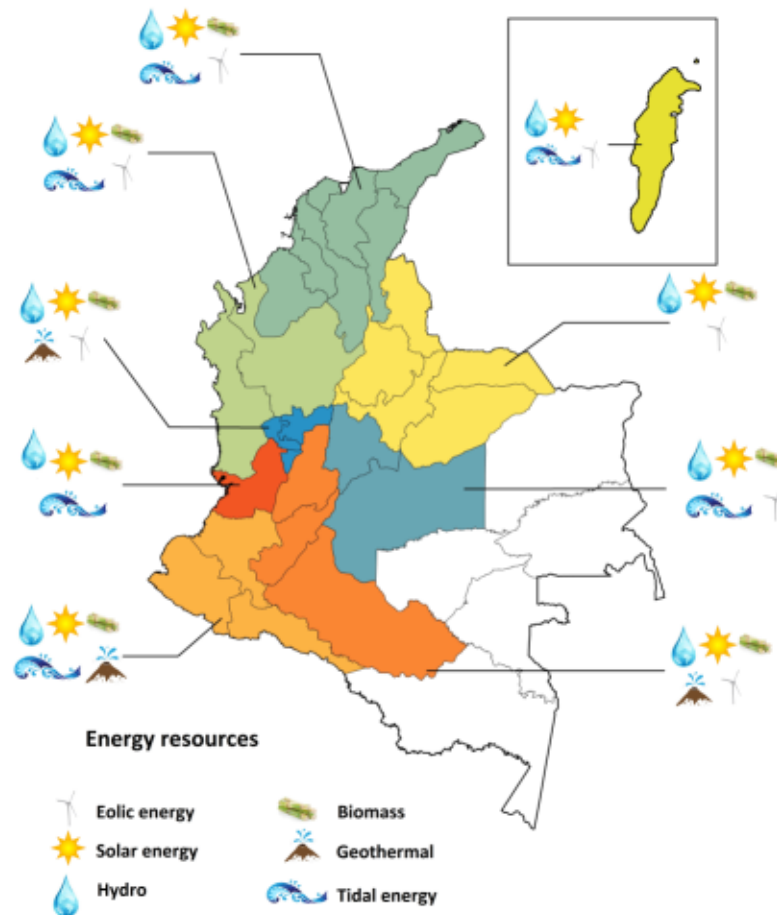

Combining local energy resources (conventional and non-conventional) and technological configurations:

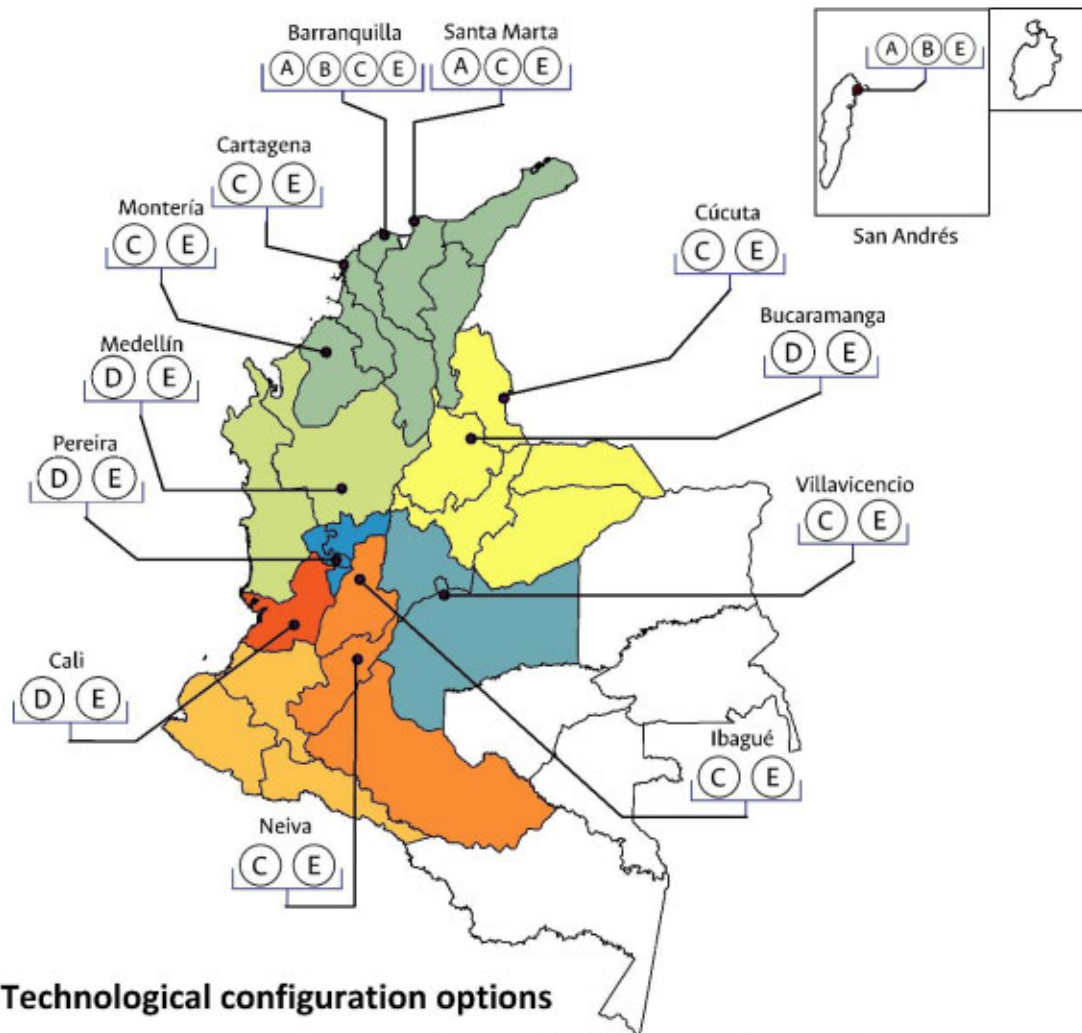

Technological configuration options

- (A) Sea Water Air Conditioning (SWAC)
- (B) Cooling with renewable energies
- (C) Natural gas cogeneration + Solar PV
- (D) Natural gas or flare gas cogeneration
- (E) Electric chiller 100%

With LEAP tool

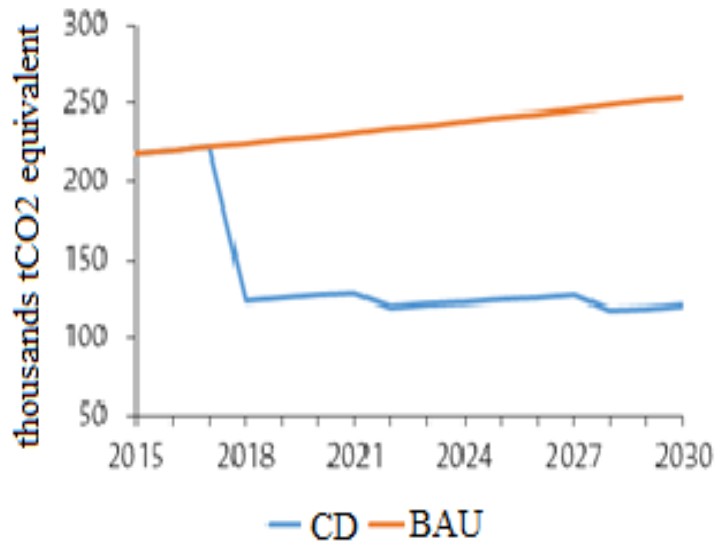

the CD scenario presents a reduction in greenhouse gas emissions with respect to the BAU: an accumulated reduction of 1,500 kTon of CO₂ equivalent for 2030 was estimated.

By comparing both scenarios at the end of the simulation, it was found that the specific reduction for the last year of the CD scenario compared to the BAU scenario is larger than 50%.

CD scenario considers the use of cogeneration system with natural gas. Using of renewable resources would increase the environmental benefits.

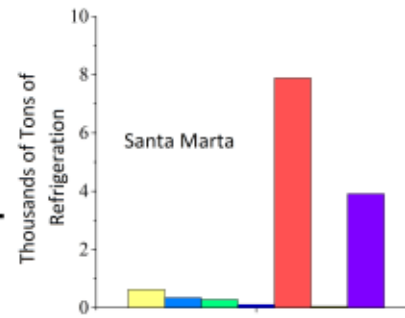
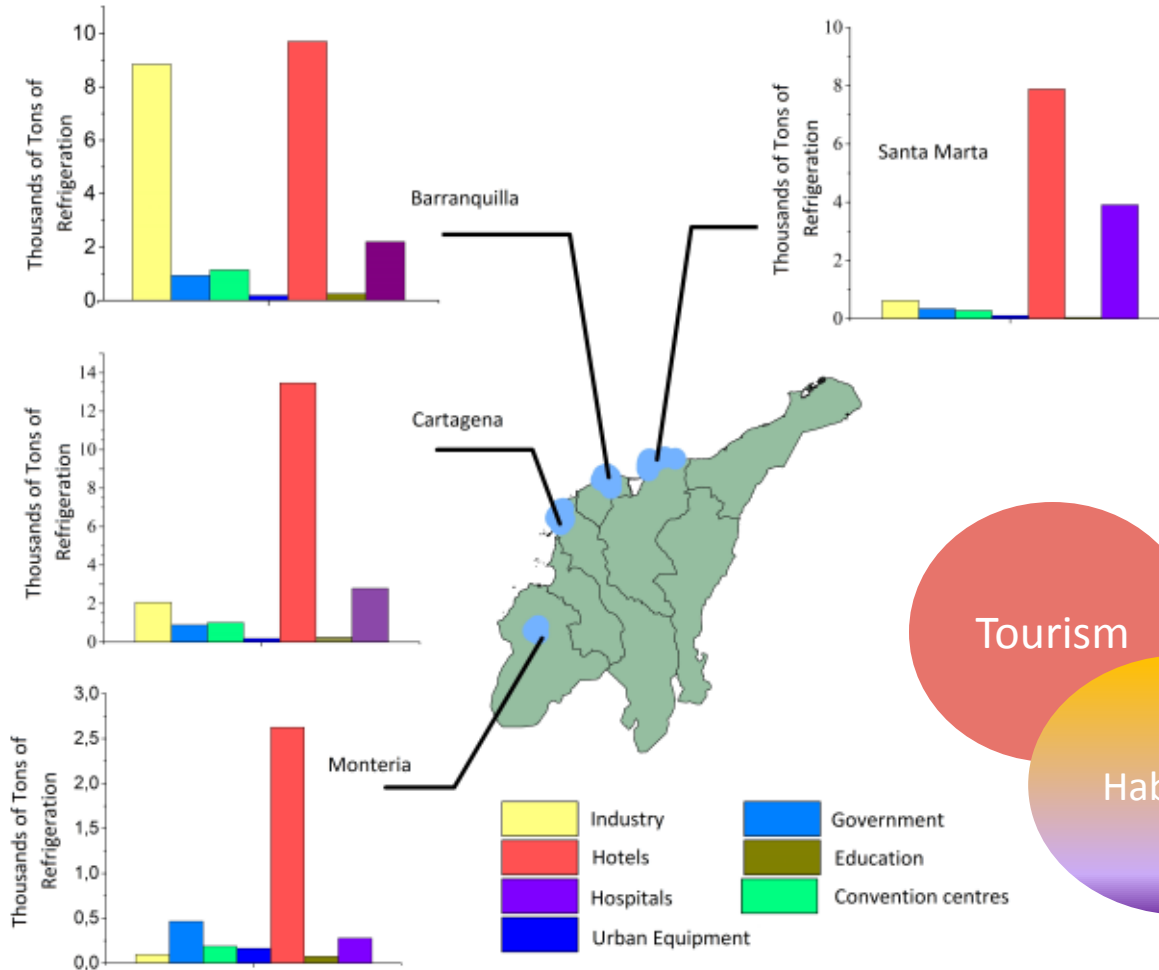

Total potential of 196,900 RT for the implementation of CDs in Colombia.

Medellín is recognised worldwide as the most innovator city, and the potential keeps being higher to install at least four CDs with about 24,000 RT.

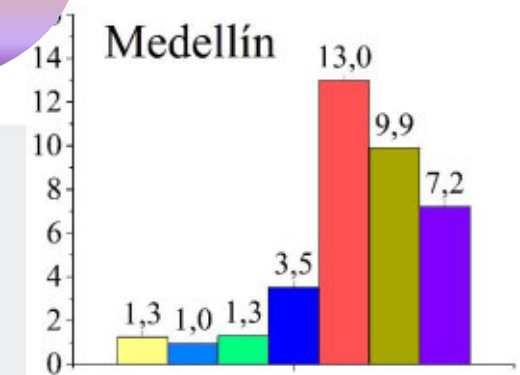
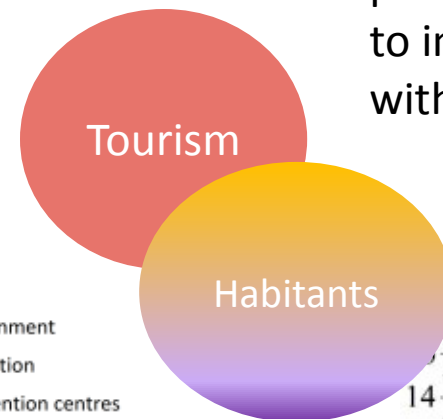

Sede Medellín

Technologies

Cogeneration

- More efficiency
- Distributed generation

Renewable energies

- Free resource
- Near to Zero emissions
- Distributed generation

Cooling District

Economies of scale

Sede Medellín

Money



Emissions

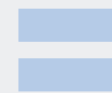

Savings

The authors which to thank to “Empresas Públicas de Medellín – EPM” who founded the project “Characterize the supply and demand of thermal energy services in Colombia; and evaluate the technical and economic substitution options from the perspective of implementing Thermal Districts projects” and to the project “Feasibility study of water heating through energy integration of solar energy and heating by submerged pipes in the National Chocolates Company” developed by U.T. INCOMBUSTION and financed by COLCIENCIAS, contract No. FOP44842-474-2016.

Thanks!!!



ISEC

INTERNATIONAL
SUSTAINABLE ENERGY
CONFERENCE 2018

3. – 5. Oktober 2018
Congress Graz
Österreich

Facultad de Minas

Dirección:

Carra 80 Nro. 65 – 223 Bloque M3 – Oficina 214

Medellín, Colombia

(+57 4) 425 53 33

cmcebal0@unal.edu.co

fchejne@unal.edu.co

medellin.unal.edu.co

Sede Medellín



UNIVERSIDAD
NACIONAL
DE COLOMBIA