



Energetically optimized gold and palladium recovery in the printed-circuit-board industry with MEMBRANE DISTILLATION

Christian Platzer

AEE - Institute for Sustainable Technologies (AEE INTEC)
8200 Gleisdorf, Feldgasse 19, AUSTRIA



Challenges

- Gold and Palladium are used for **surface treatment** in **electroplating processes** in the printed circuit board (**PCB**) industry
- Galvanic ingredients **Gold** and **Palladium** are **lost** with the **rinsing water**
- Due to the lack of efficient recovery technologies, these valuable metals **could not brought back to the Process** again

Agenda

- The Key-Technology „Membran Distillation“
- Introduction of AT&S AG - Status Quo and Problem settings in the Printed Circuit Board (**PCBs**) Industry
- Project MD- Gold:
Solution Proposal and Objectives to be achieved

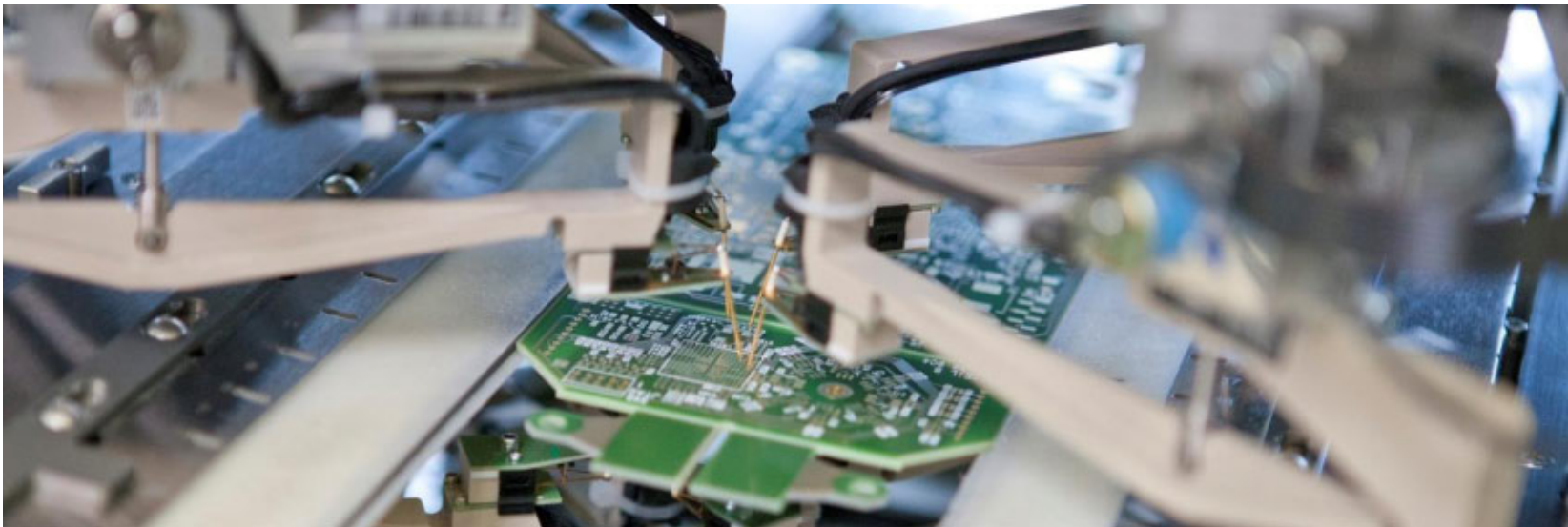

Key Technology - Membran Destillation (MD)



Quelle: <http://www.hotel-seelos.at/aktivitaten/winter/schifahren/>

Waterproof and Breathable

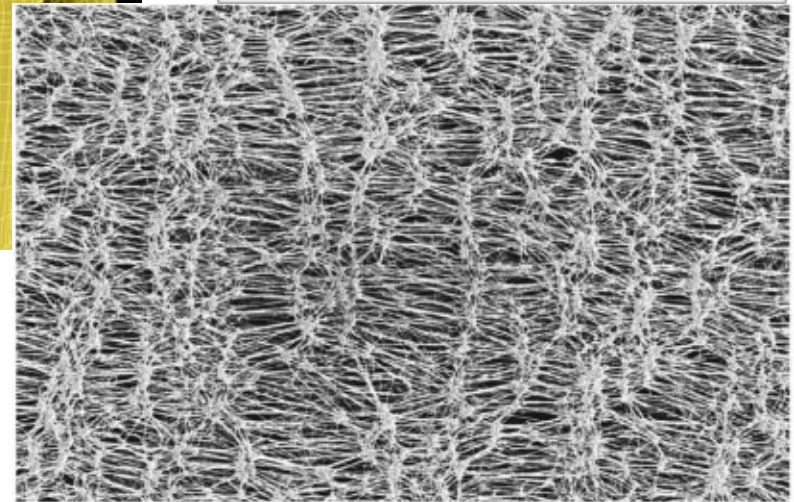
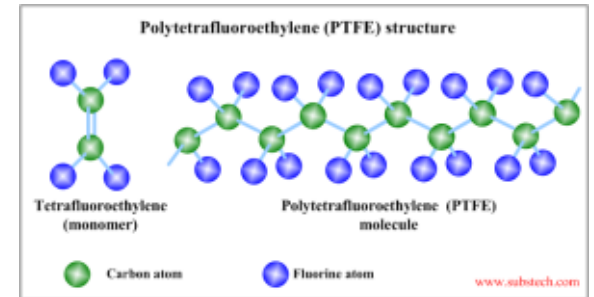
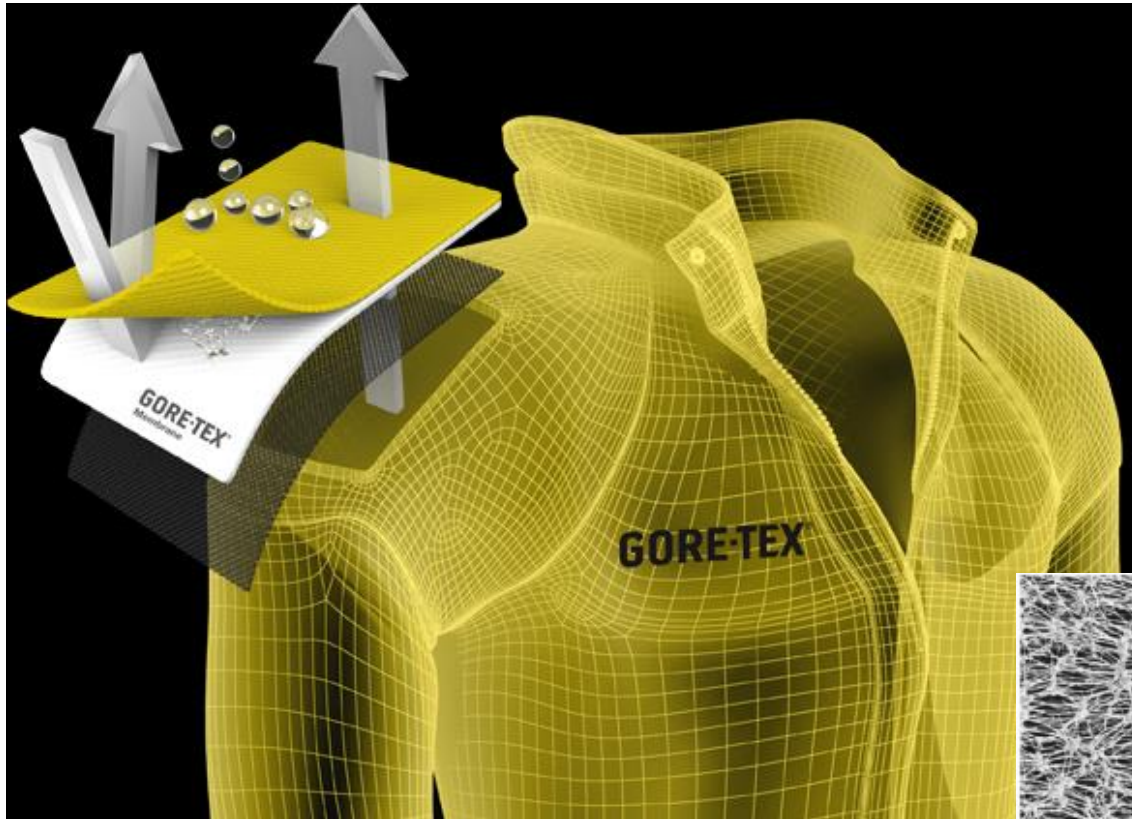

Quelle: <http://www.gore.com>

Membrandestillation (MD)

= thermal Separation Process

- For separating vaporous molecules from liquids
- Atmospheric Pressure
- Driving force: **vapor pressure difference** (temperature difference ΔT between **Feed** und **Permeate**)

Benefits:

- ✓ Evaporation at low Temperatures (30- 90°C)
- ✓ Ideal for the use of waste heat (industry) and solar energy

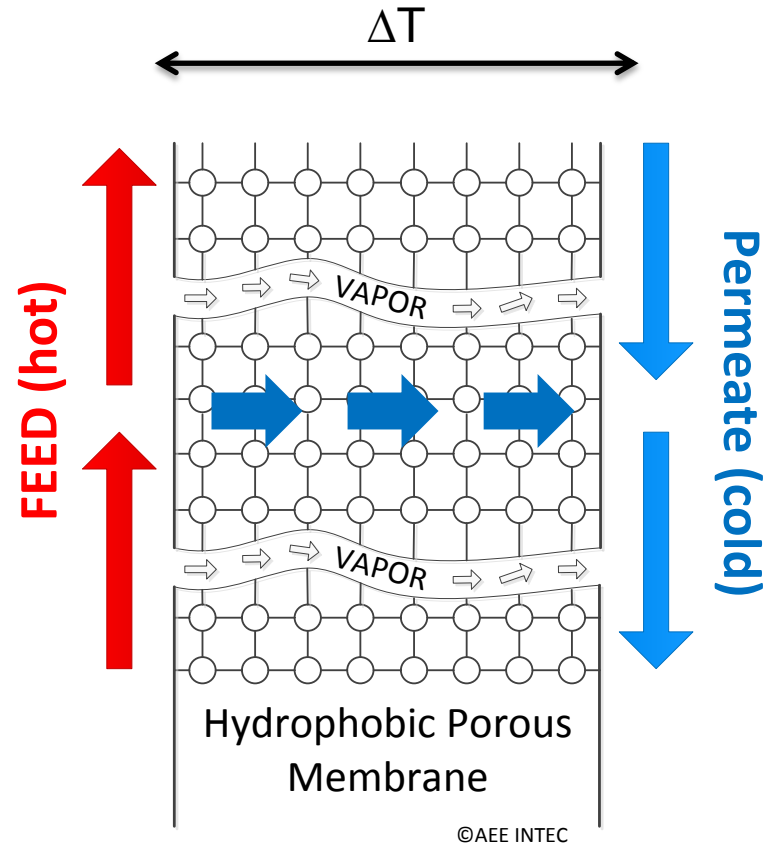



Project MD-Gold

Consortium



AEE - Institut für Nachhaltige Technologien
|Feldgasse 19 | 8200 Gleisdorf



**AT & S Austria Technologie & Systemtechnik
Aktiengesellschaft**
|Industriepark 4 | 8350 Fehring



Rotreat Abwasserreinigung GmbH
|Otto-Baumgartnerstraße 7 | A-8055 Graz–Neuseiersberg

Challenges

- Galvanic ingredients **Gold** and **Palladium** are **lost** with the **rinsing water**
- Recovery requires efficient Systems for the **Concentration of liquid Substances**
- an **energy-efficient** (CO₂ neutral) and sustainable process for recovering the critical raw materials gold and palladium from the processes of circuit board production is needed
- **Membrane distillation** (MD) is a thermal separation process at a low temperature level (**Waste Heat driven**)

Disadvantages of Conventional Membrane Technologies

- **pressure-driven** membrane technologies
e.g. reverse osmosis and micro-, ultra- and nanofiltration

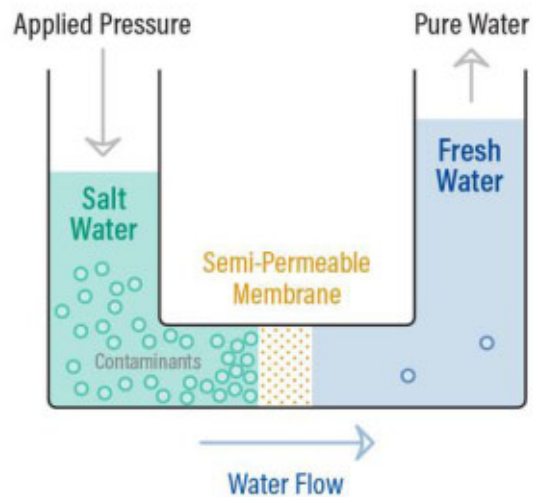

- High Electric **Energy Demand**
→ no CO₂ and **climate-neutral energy** supply possible
- Treatment of treatment of strongly **acidic** and **alkaline** liquids **not possible**

Case GOLD Plating – Status Quo

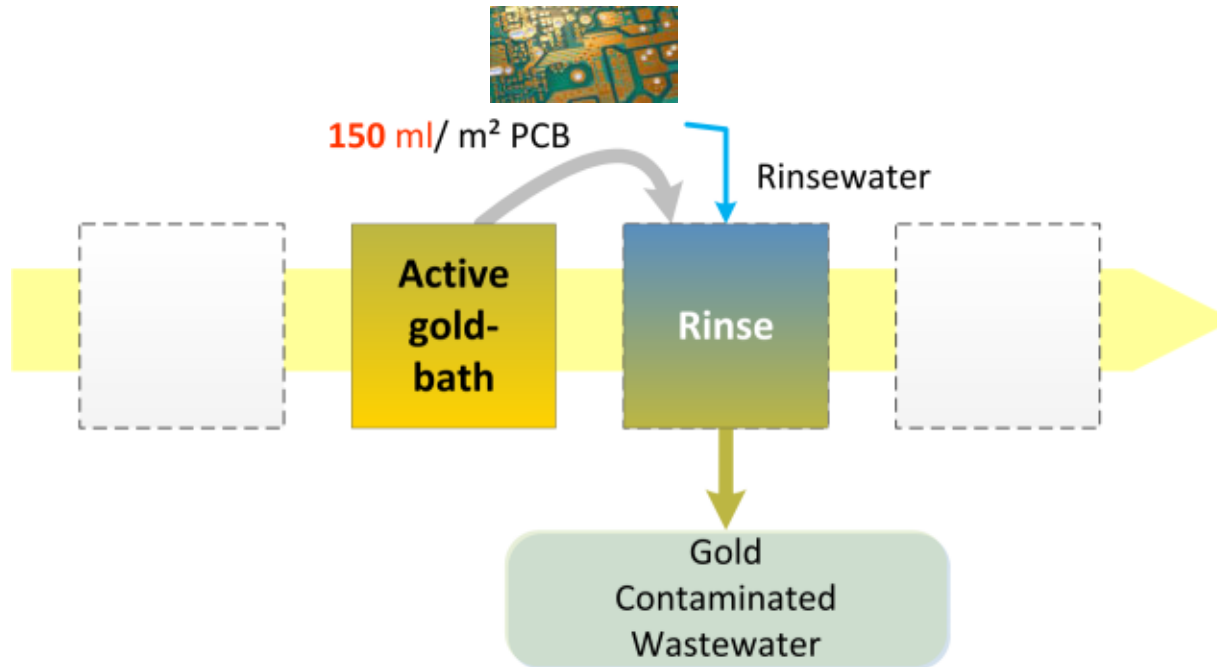

- **Objective:**
 - reduction of gold demand / losses
 - closure of the water cycle

Solution „GOLD“ Resource Recovery in Active Gold Bath

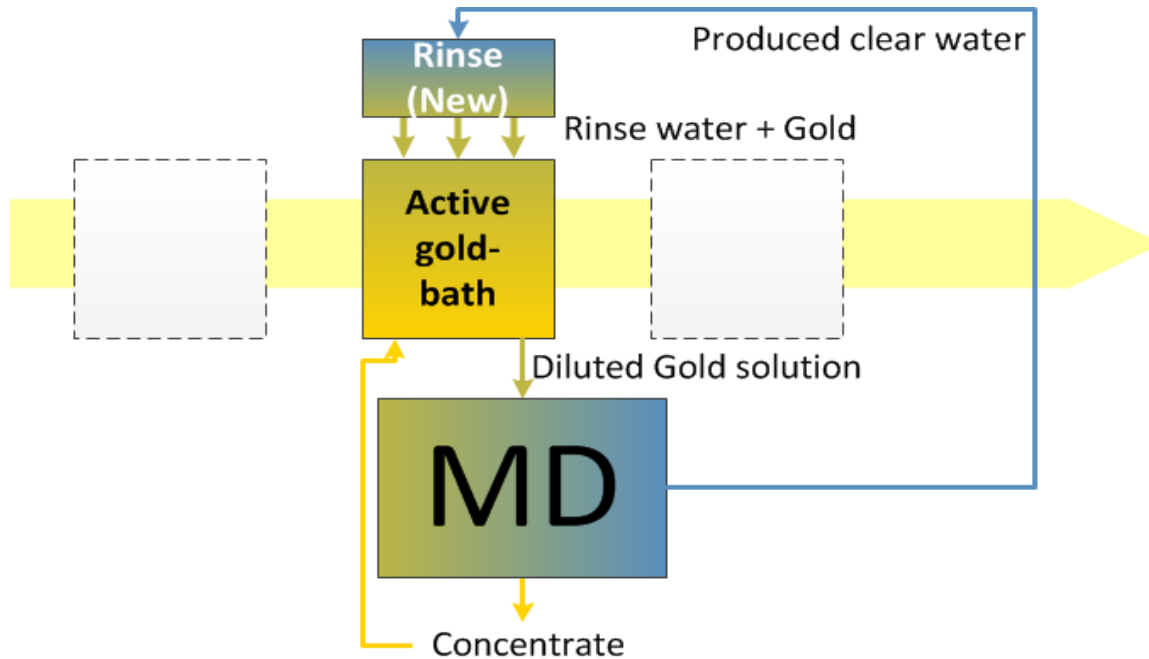

- **Adaption of the Process**
Rinsing above the Active Gold Bath
- **Separation of the Rinsing Water with MD**
- **Recovering & Reuse of the Rinse Water**

Projekt MD-GOLD

Method of MD-Technology Development

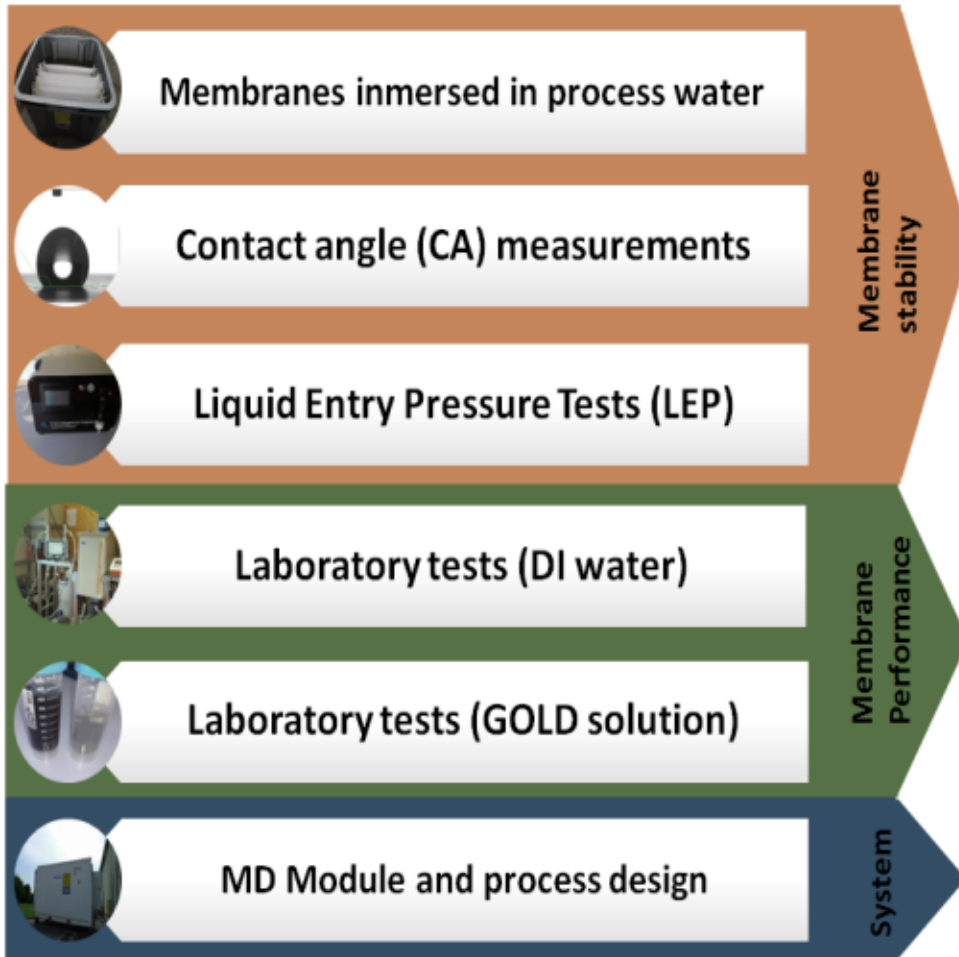

- Suitable Membrane identified
- Chemical Stability proved

- Optimal MD-Operating Parameters defined
 - ✓ Gold solution reusable
 - ✓ Permeate reusable

- Optimized Module Design
- System Integration and Energy Concept

Experimental Setup – MD plant in laboratory Scale

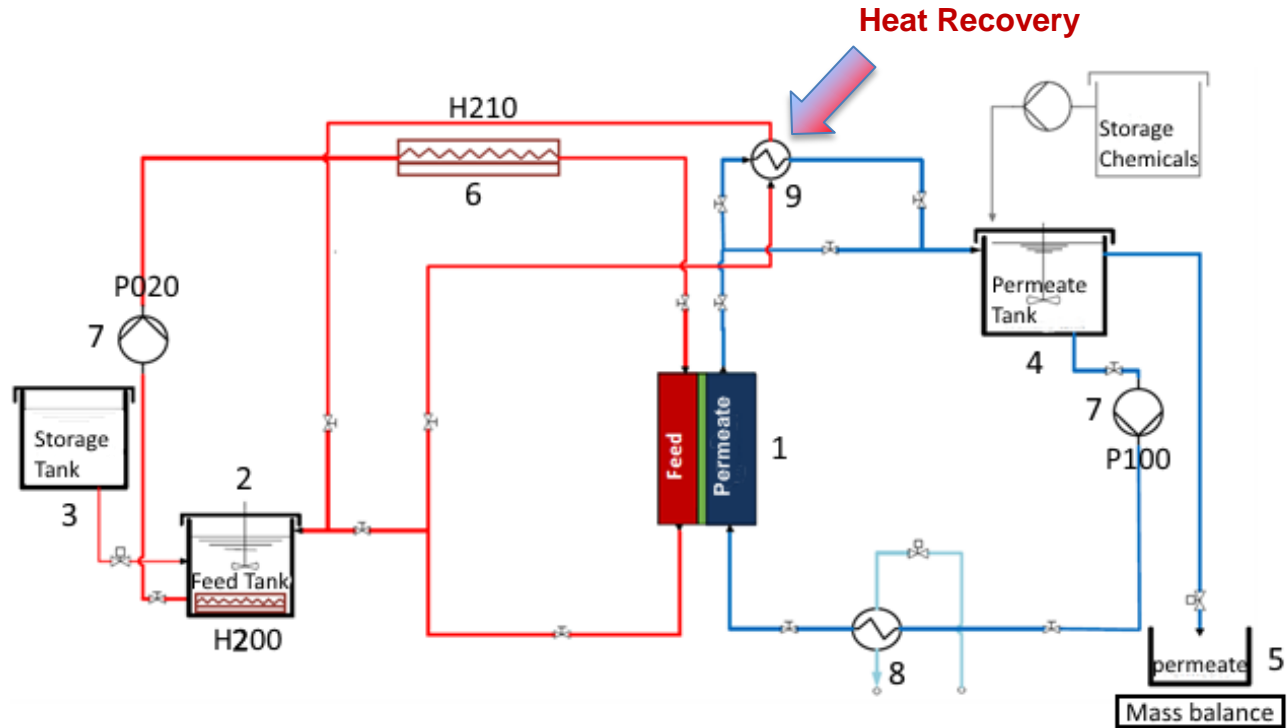

- **Temperature** Feed & Permeat - ΔT
- **Pressure** Feed & Permeat - Δp
- **Flow rate** Feed & Permeat – $L \cdot h^{-1}$

- **Conductivity** Feed & Permeat - SRF
- **pH** Feed and Permeat
- **Level** Storage tank & **Mass balance** - $L \cdot min^{-1}$

Technical quality (Suitability) of recycled liquids

Analyzation results proofed:

- Gold solution reusable
- Permeate reusable in rinsing

Quality test & plating of gold solution

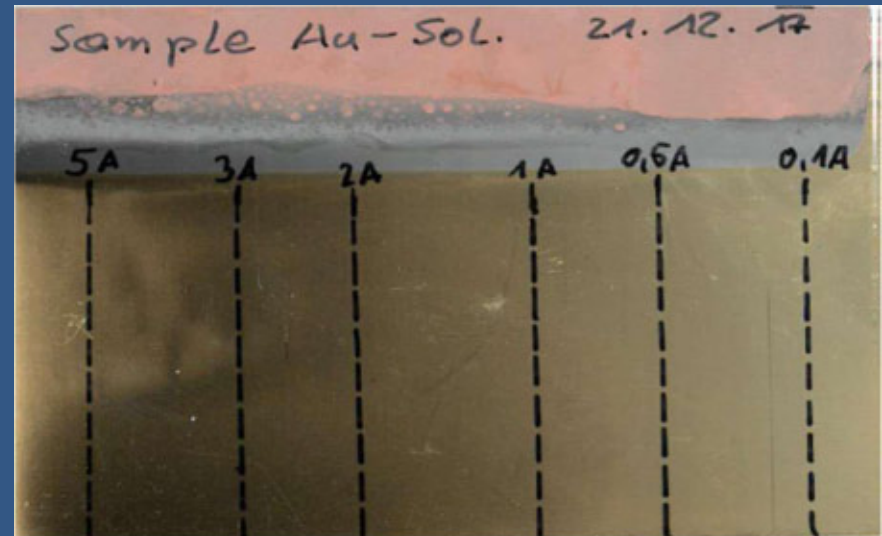
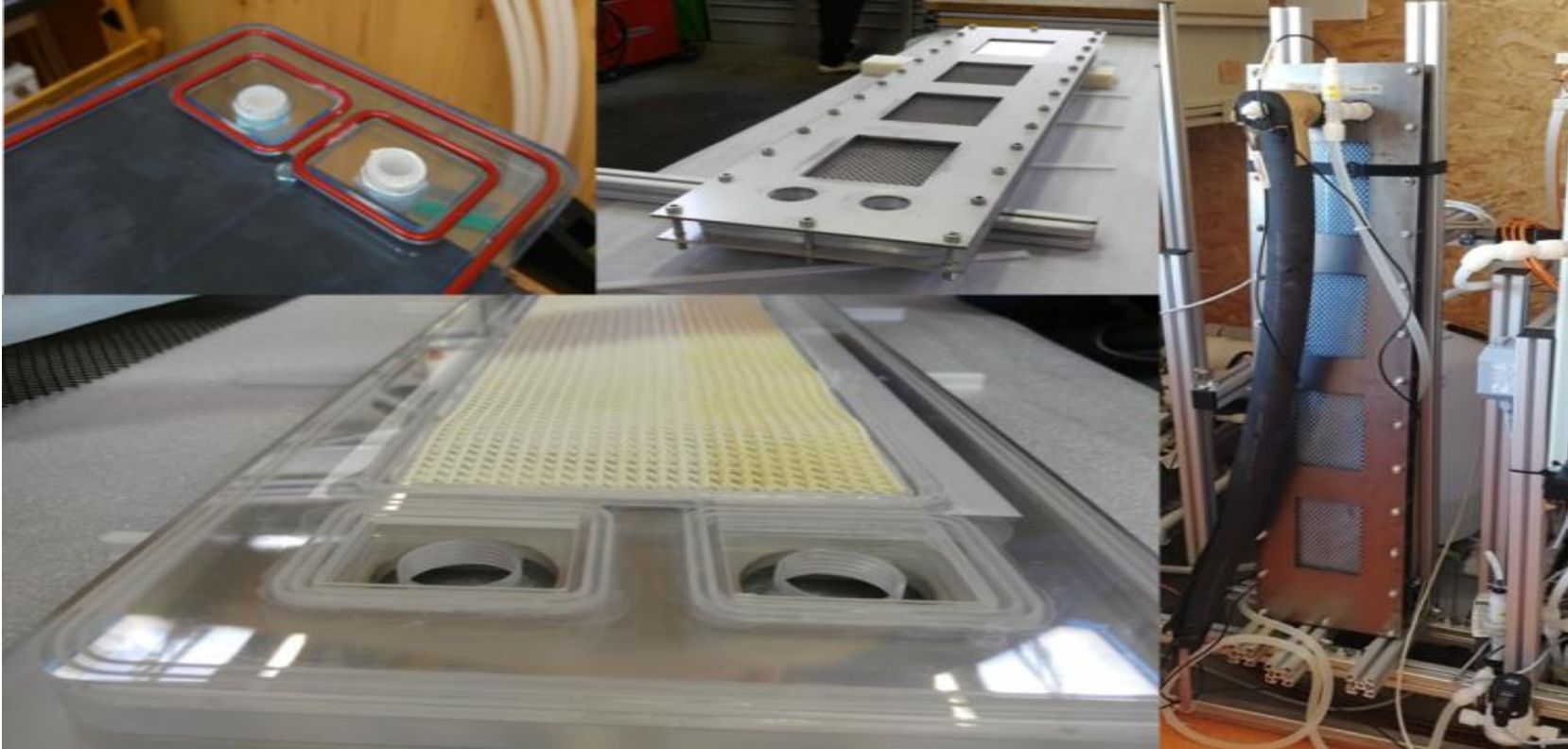

Figure: PCB Plating Tests with recycled Gold Solution
(AT&S, 2018)

MD - Membrane Module Development



- Optimized Module Design

System Integration and Energy Concept „Cost- and CO2 neutral“

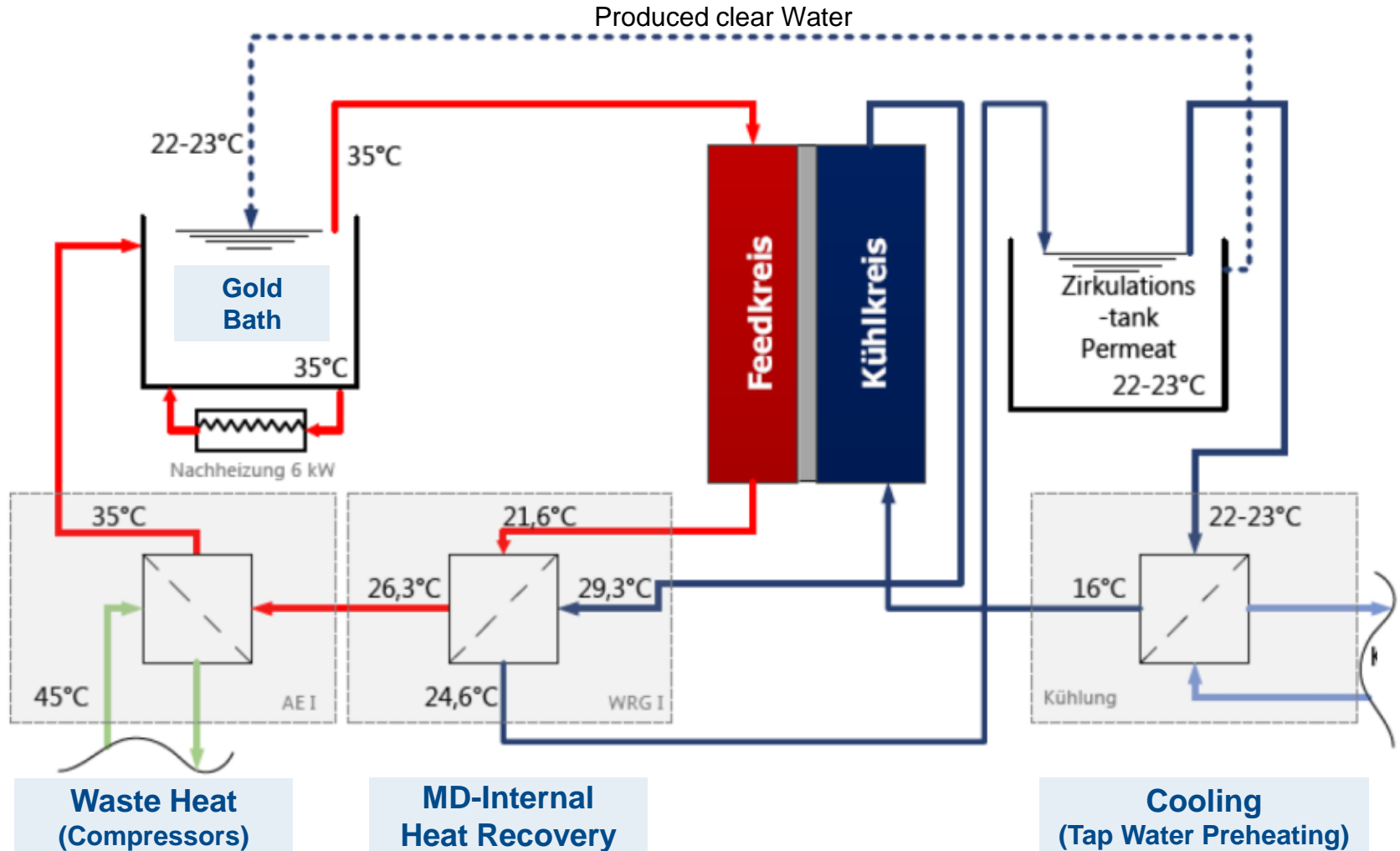

Benefit Gain - AT&S Location Fehring

“Case Gold”

- Potential of annual **Cost Reduction** EUR 149,500
- **Wastewater Reduction** of around 1,450 m³ / a



Reduction of Potassium-Gold-Cyanide Discharge by ~ **80%**

Quelle: Rotreat Abwasserreinigungs GmbH.

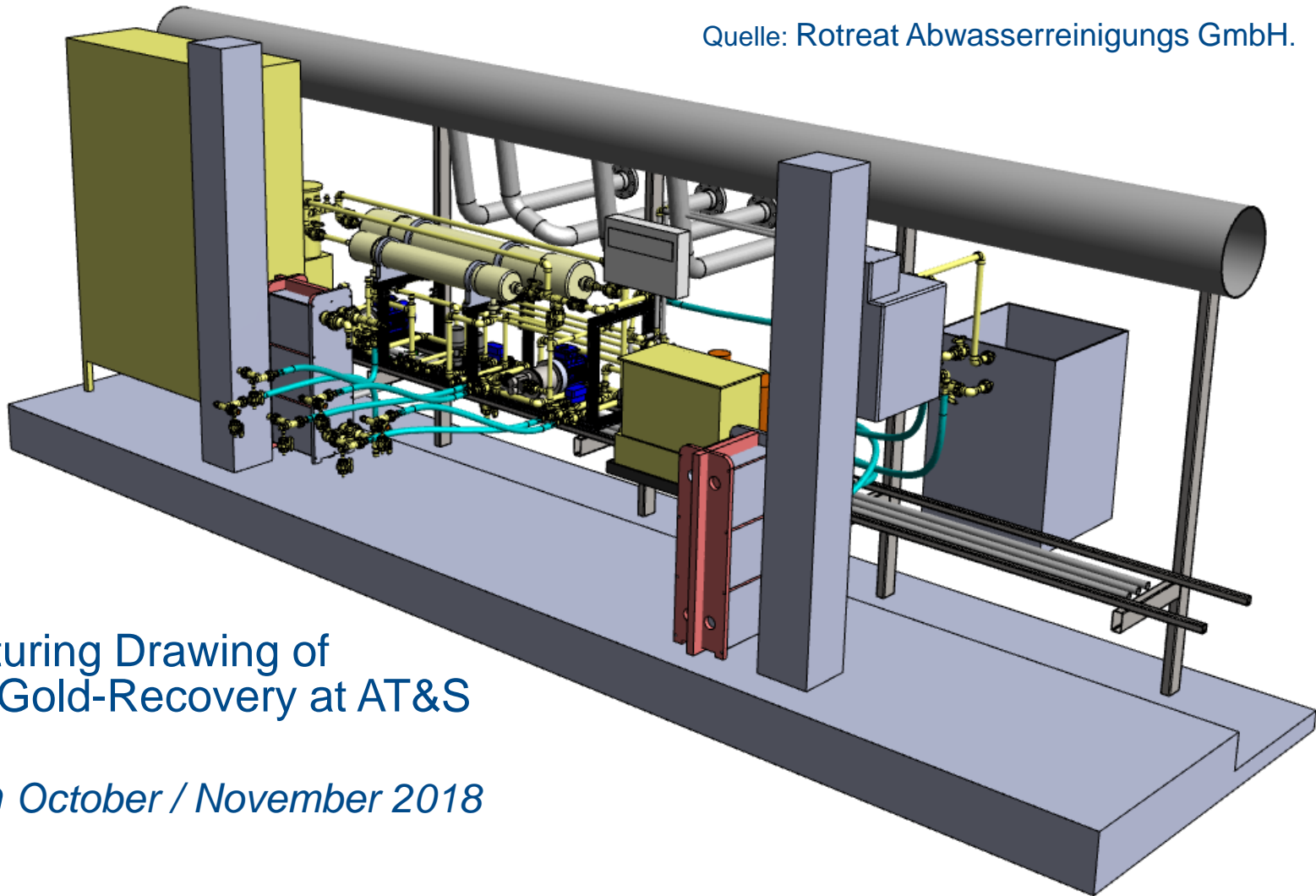

3-D Manufacturing Drawing of
MD-Plant for Gold-Recovery at AT&S

Realization in October / November 2018

An aerial photograph of a modern building complex with a prominent solar panel array on the roof. The building has a mix of grey, blue, and yellow facades. A yellow and blue logo is overlaid on the top left, and a white banner with blue text is overlaid on the middle left. The scene is set against a clear blue sky with some light clouds.

AEE INTEC

IDEA TO ACTION

**Thank you
for your Attention**