

# MUNICIPAL WASTEWATER TREATMENT SYSTEMS AND THEIR FUTURE ROLE IN EFFICIENT AND SUSTAINABLE ENERGY SYSTEMS

Kerstin Schopf

DEPARTMENT FÜR  
*Umwelt- & Energieverfahrenstechnik*

# INTRODUCTION

*“To combat climate change it is necessary to establish efficient and sustainable energy systems within the energy transition.”*

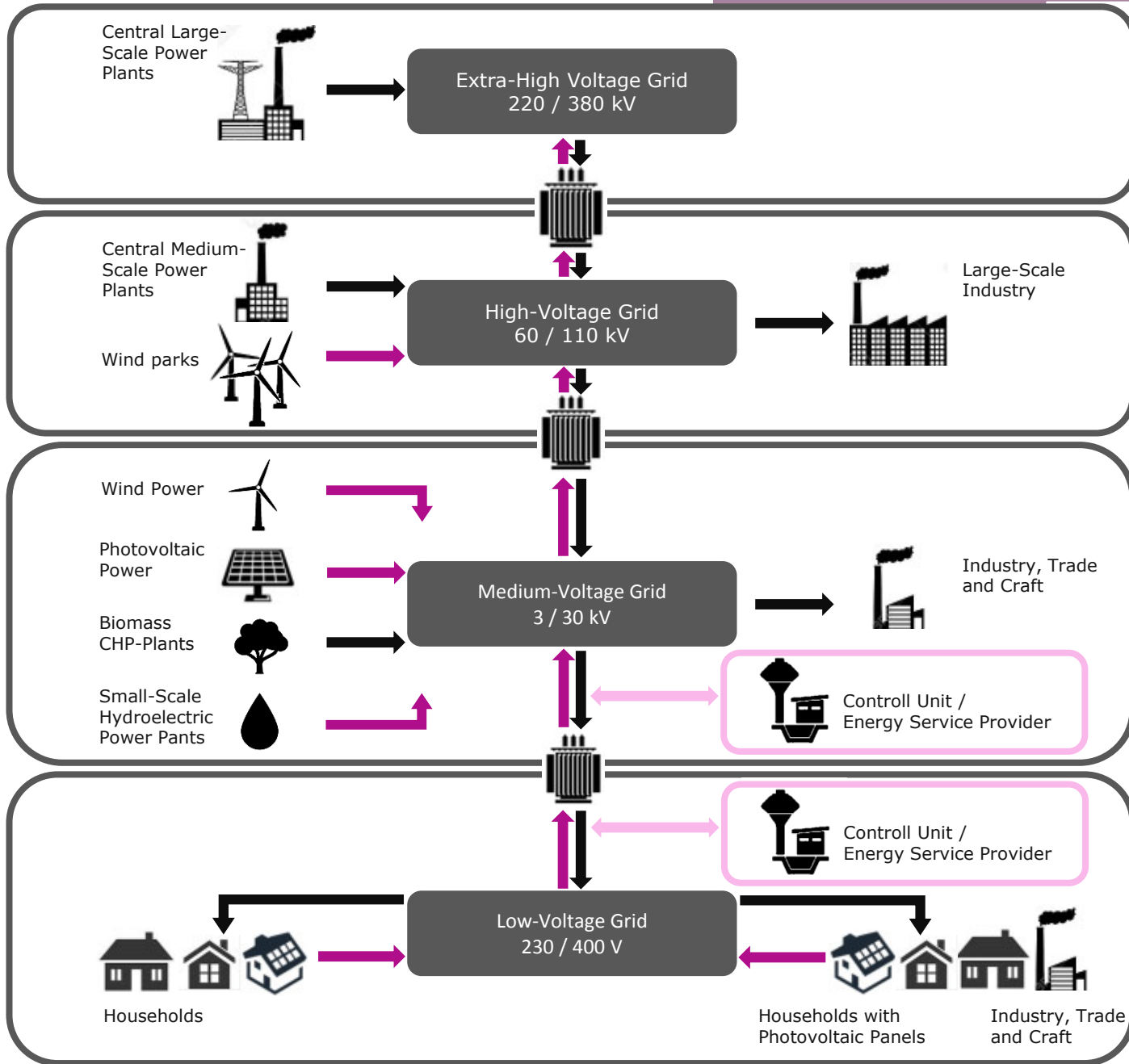

# INTRODUCTION

## CONTROLL UNIT / ENERGY SERVICE PROVIDER



### ENERGY SERVICES OF WASTEWATER TREATMENT PLANTS...

- ...Constant electric or thermal energy supply
- ...Frequency reserve

### POTENTIAL DEPENDS ON...

- ...the energy intensive units,
- ...the amount of bioenergy potentials
  - digester gas and sewage sludge
- ...the storage possibilities
- ...the flexible useable units.

# METHODOLOGY

## OPTIEVLEX

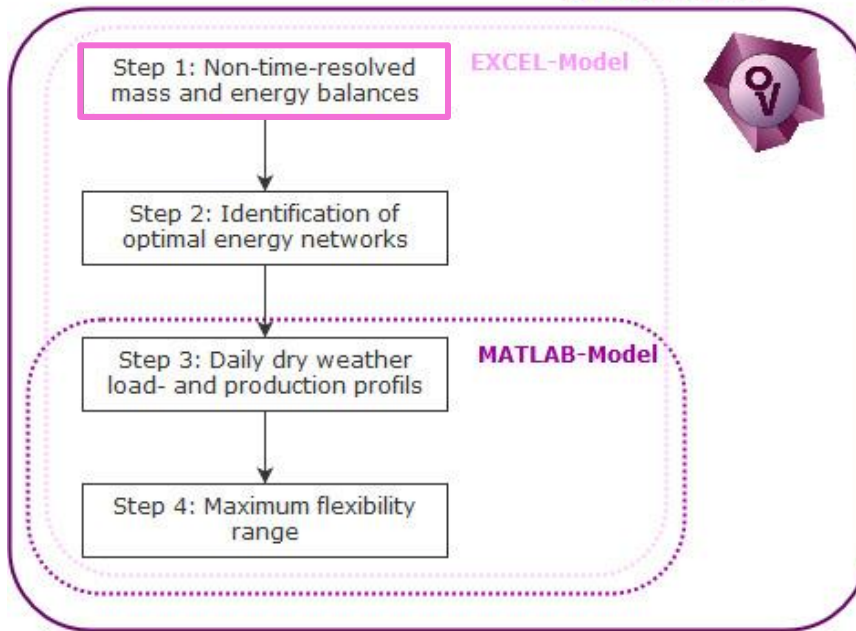

- Energy demand = ?
- Amount of bioenergy potentials = ?

## MASS AND ENERGY BALANCES OF WASTE WATER TREATMENT PLANTS

- Depend on...
  - Plant size
  - Treatment technology
  - Sewage composition

# METHODOLOGY

## STEP 1: Non-time-resolved mass and energy balances

Modular structure for considering different plant configurations

- Excel-based data collection
- Calculation of all treatment processes up to the dewatering unit
- Focus on aerobic and anaerobic treatment plants
- Standardized formulary

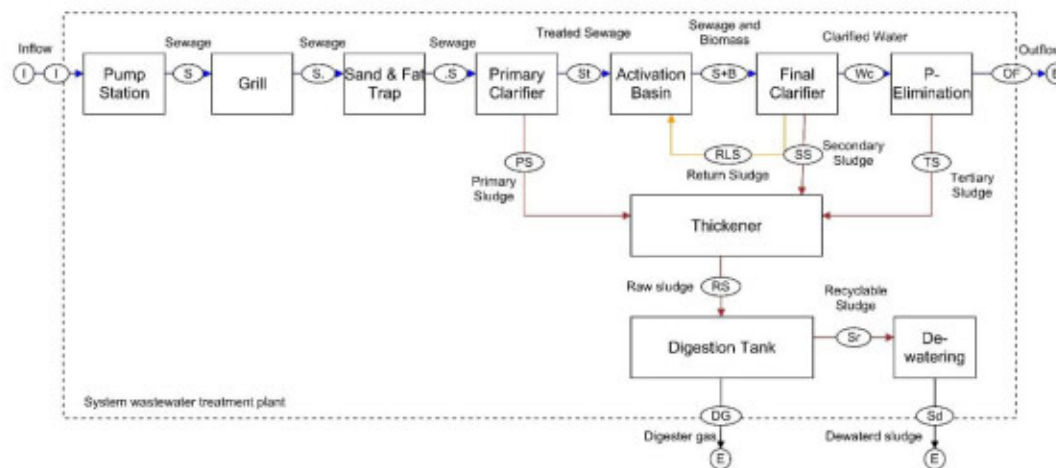

# METHODOLOGY

## OPTIEVLEX

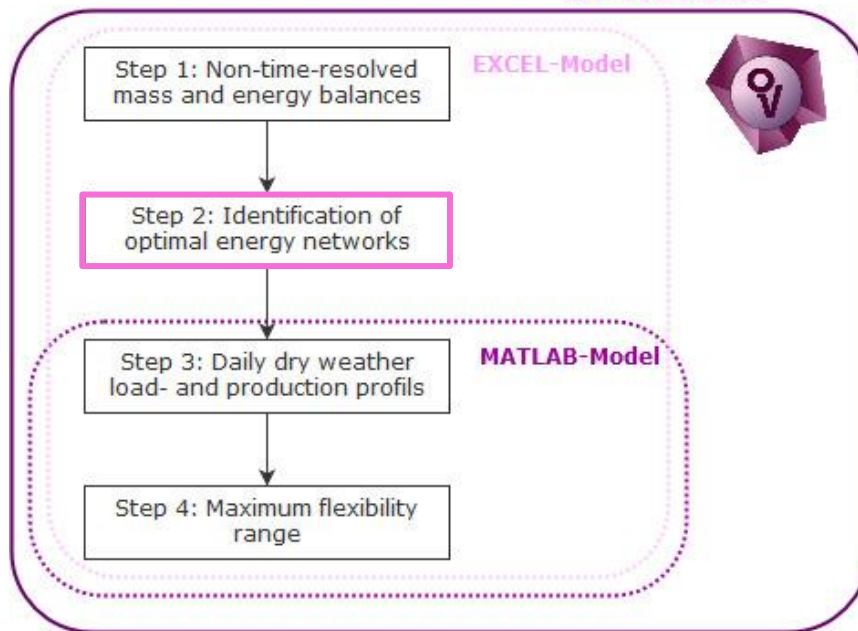

- Integration of bioenergy potentials = ?

## DECENTRALISED ENERGY PRODUCTION ON-SITE

- Analysing the potential for supplying electric and thermal energy by digester gas and sewage sludge utilisation
- Role as energy service providers in medium- and low-voltage grids

# METHODOLOGY

## STEP 2: Designing energy networks

Expansion of the non-time resolved modular tool

- Digester gas utilisation by CHP-units, micro gas turbines or gas boilers
- Sewage sludge utilisation by combustion or gasification

▫ No state-of-the-art technology

▫ Assumptions:

8,000 operating hours

Compatibility

Optimal output quality

▫ Cooperation partner:

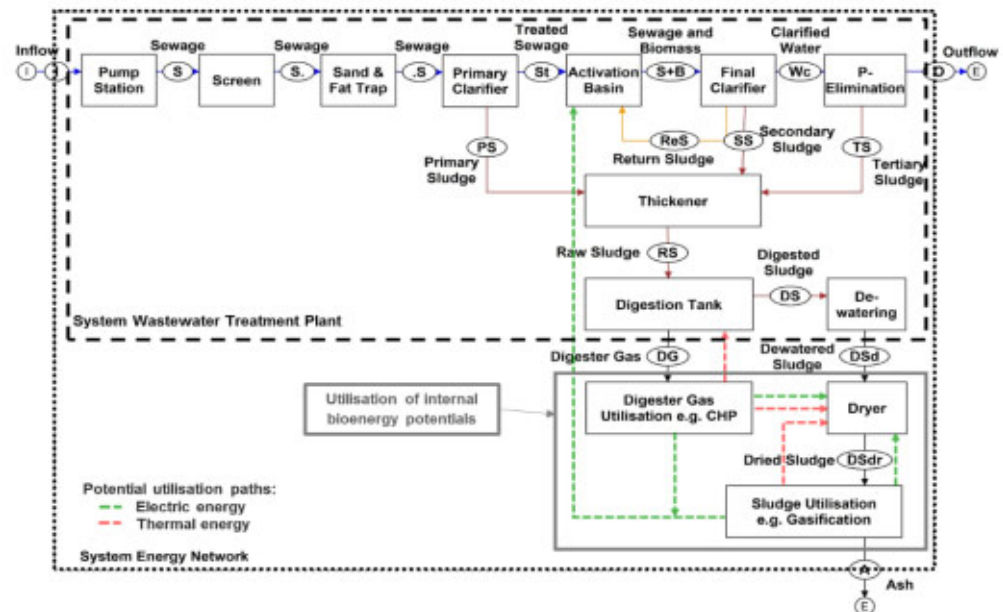

# METHODOLOGY

## OPTIEVLEX

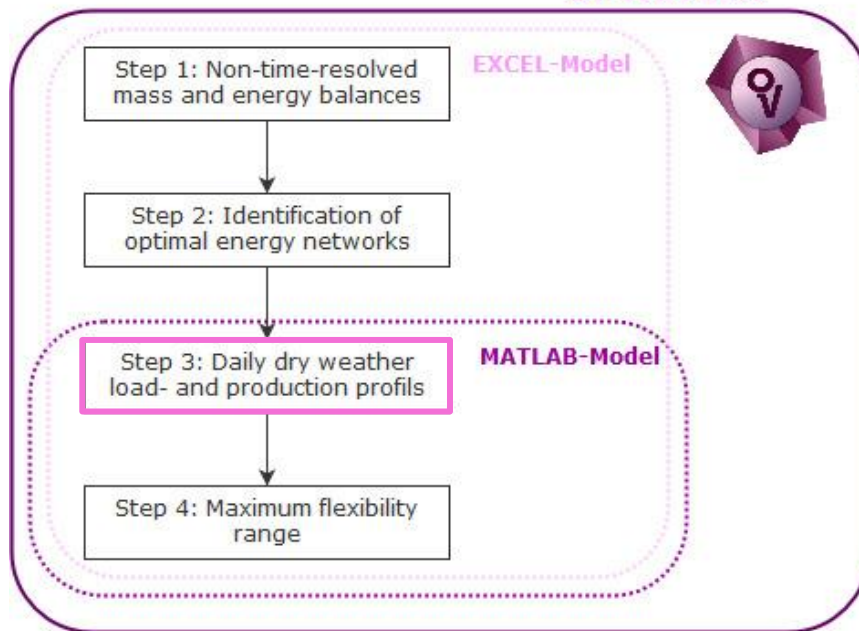

- Time dependencies = ?

## TIME-RESOLVED LOAD AND PRODUCTION PROFILES

- Identifying real interaction possibilities with medium- and low voltage grids

# METHODOLOGY

## STEP 3: Daily dry weather load- and production profiles

Expansion of the EXCEL-Tool by a time-resolved inflow model via MATLAB

- Dry weather inflow model of the “Hochschulgruppe Simulation”
- Transferred to a MATLAB script

Dry weather inflow [m<sup>3</sup>/h]  
(100.000 PE)

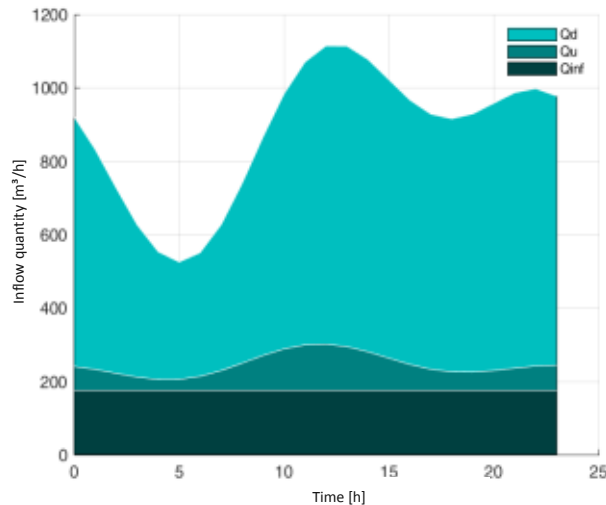

Sewage Composition [g/m<sup>3</sup>]  
(100.000 PE)

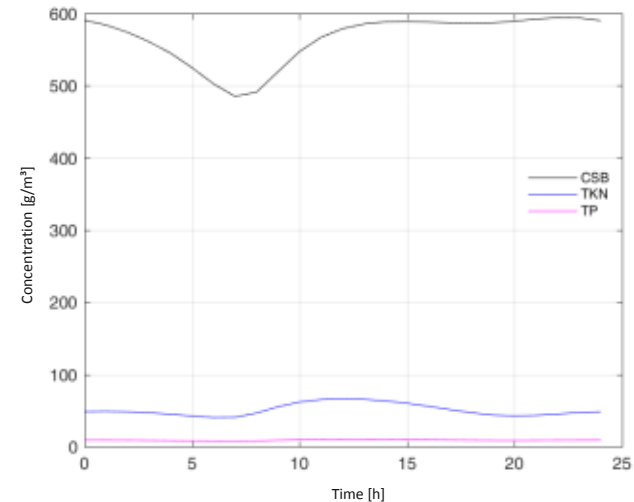

# METHODOLOGY

## OPTIEVLEX

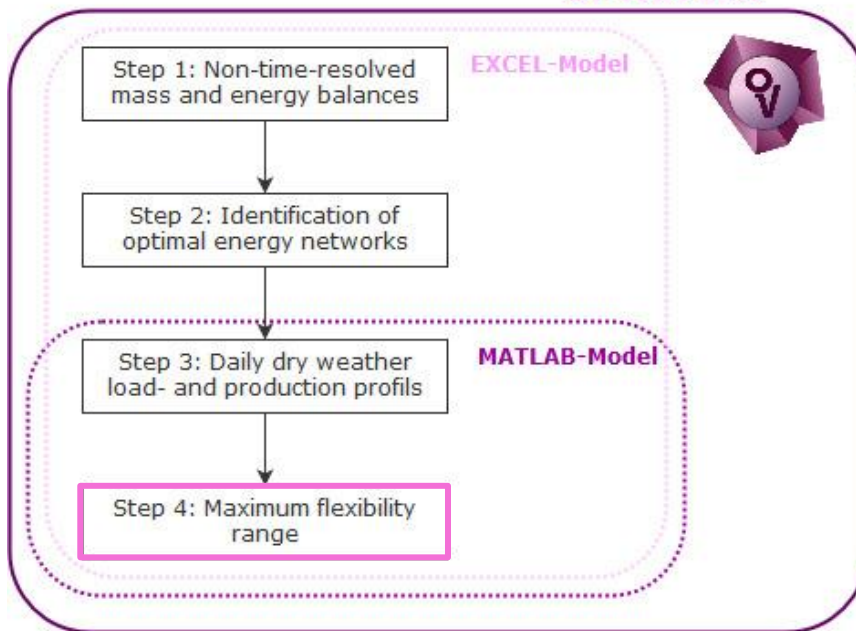

- Flexible useable units = ?
- Flexibility potential = ?

## MAXIMUM FLEXIBILITY RANGE

- Identifying the maximum flexibility potentials of a waste water treatment plant by constant purification performance

# METHODOLOGY

## STEP 4: Maximum flexibility range

Five decisive factors concerning the flexibility potential

- High electric and thermal energy self-sufficiency
- Minimal available power
  - Low-voltage grids: > 5 kW
  - Medium-voltage grids: > 50 kW
- Deactivation time and responds speed of the units
  - Respond speed: max. 5 minutes
  - Deactivation time: min 15 minutes
- Full-load hours of the units
- Availability of storage possibilities for digester gas and sewage sludge

→ Pump station, blower sand trap, blower aeration tank, recirculation pump, return sludge pump, CHP-units

# METHODOLOGY

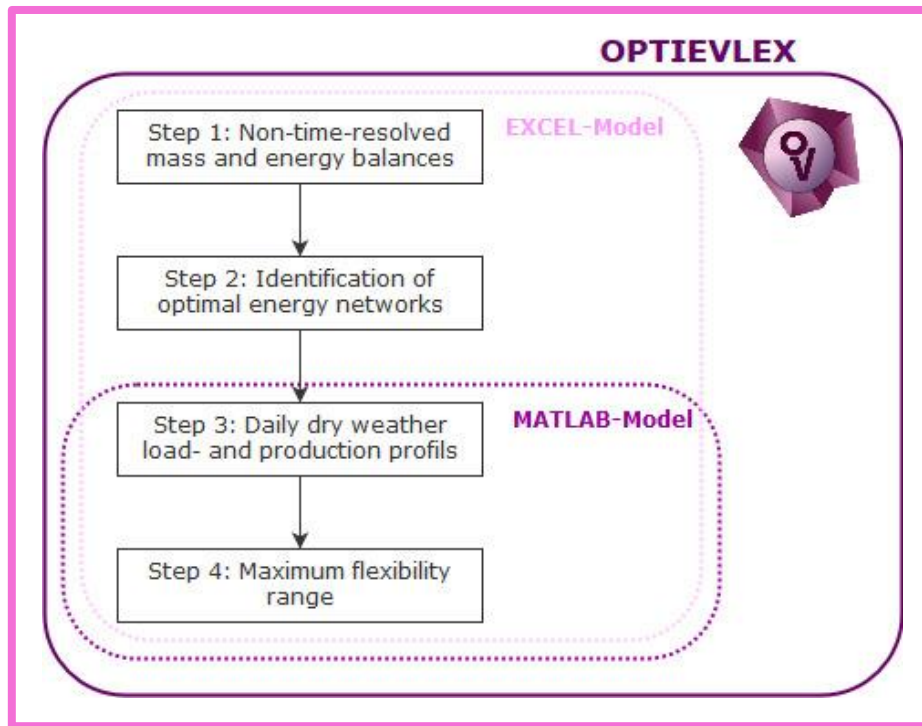

Standalone application  
**OPTIEVLEX**

**“OPTIMIERTE  
ENERGIEVERBUNDE  
KOMMUNALER ABWASSER-  
BEHANDLUNGSANLAGEN ALS  
FLEXIBILITÄTSBAUSTEIN IN DEN  
KOMMUNALEN NETZEN DER  
ZUKUNFT”**

# METHODOLOGY

## Standalone application OPTIEVLEX

Enables to...

- Time-resolved and Non-time-resolved simulations
- Calculation of the mass and energy balances of user-defined waste water treatment system configurations
- Determination of the energy self-sufficiency
- Estimation of load and production profiles
- Derivation of maximum flexibility ranges

## 6. Get results

The screenshot shows the OPTIEVLEX software interface. At the top, there's a title bar 'OPTIEVLEX\_Version10'. Below it, a header area contains the 'OPTIEVLEX Tool' logo and a description: 'Optimierte Energieverbunde von kommunalen Abwasserbehandlungsprozessen als Flexibilitätsbaustein in kommunalen Energiesystemen der Zukunft'. A 'Hilfe' button is visible on the right.

The main interface has four tabs: '1. Allgemeine Spezifikation', '2. Dateneingabe', '3. Betriebsstundenoptimierung', and '4. Kalkulation'. The '4. Kalkulation' tab is active.

Below the tabs, there's a section 'Datenzusammenfassung und Simulationsstart:'. It is divided into two columns: 'Zusammenfassung' and 'Verfügbare Diagramme'.

**Zusammenfassung:**

- Dynamische Simulation
- Speichername: Ergebnisdatensammlung.xlsx
- Inputwerte:
  - PE = 100000
  - Qm = 875 m³/h
  - CODm = 570 mg/l
  - TKNm = 52 mg/l
  - TPm = 9 mg/l
- Stündliche Messung

**Verfügbare Diagramme:**

- Konzentrationsverlauf CSB, P, N
- Zuflussmengen (kumulativ)
- Regelleistungsanalyse
- Lastverlauf der gesamten Anlage** (highlighted)

Below the diagrams, there's a description: 'Darstellung des gesamten Lastverlaufes: Kumulierte Lasten aller Aggregate der simulierten Abwasserreinigungsanlage ohne Berücksichtigung der Betriebsstundenoptimierung'. A button '+ Ausgewähltes Diagramm speichern' is at the bottom.

The graph shows 'Leistungsaufwand der Anlage [kW]' on the y-axis (ranging from 300 to 420) and 'Zeit [h]' on the x-axis (ranging from 0 to 25). The curve shows a fluctuating power demand, starting around 320 kW, dipping to 310 kW at 5h, then rising to a peak of 400 kW at 10h, dipping to 370 kW at 12h, rising to another peak of 400 kW at 15h, and then settling around 320 kW after 20h.

At the bottom, there's a 'Status: Bereit' indicator, a 'Version 10.2 | Juli 2018' label, and two buttons: 'Start Simulation' and 'Abbrechen'.

# RESULTS

## OPTIEVLEX

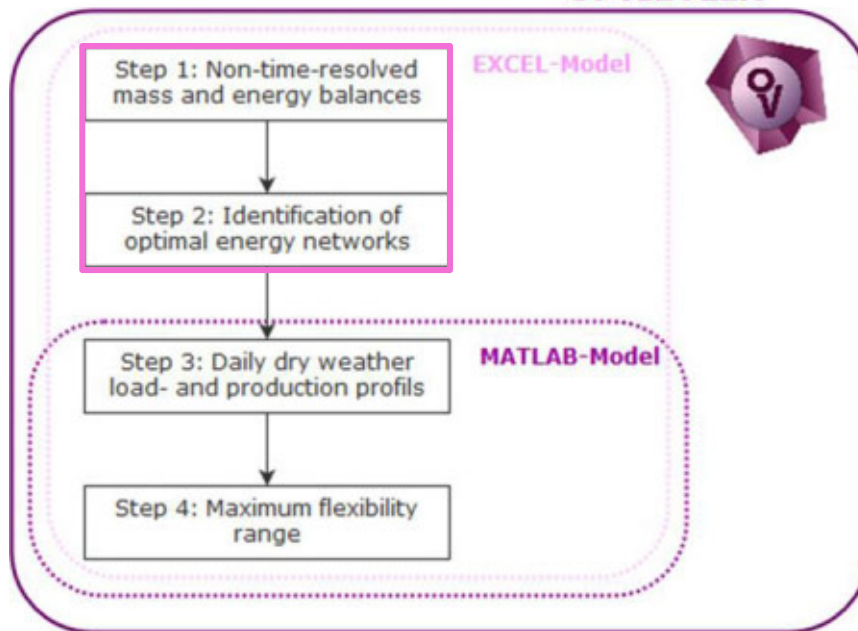

- Energy self-sufficiency is important parameter concerning the flexibility potential
- Mass and energy balances of different plant configurations:
  - Configuration 1: Anaerobic WWTP + Digester gas CHP-unit
  - Configuration 2: Anaerobic WWTP + Digester gas CHP-unit + LT-Belt-dryer
  - Configuration 3: Anaerobic WWTP + Digester gas CHP-unit + LT-Belt-dryer + Gasification + Syngas CHP-unit

# RESULTS AFTER STEP 2 - ELECTRIC ENERGY SELF-SUFFICIENCY

## Output of a static simulation with OPTIEVLEX

- Average system units and different plant capacities
- Austrian effluent limit values

Electric energy self-sufficiency

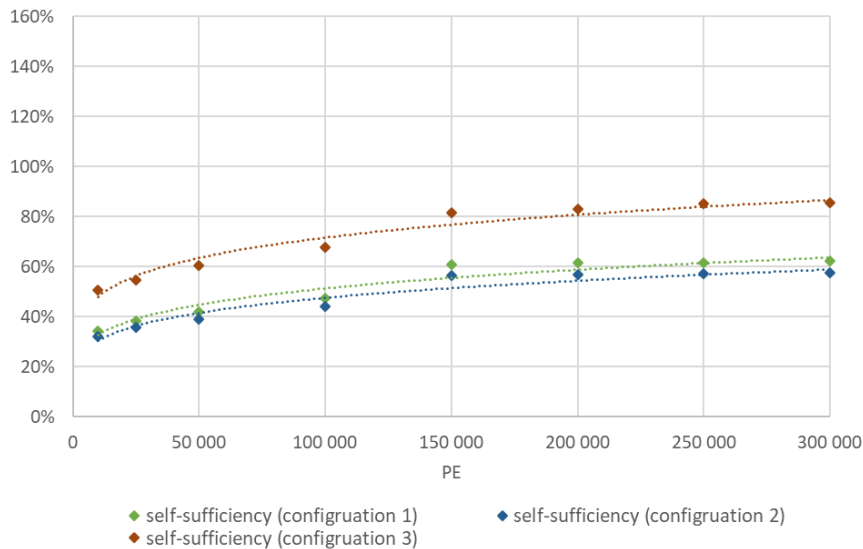

Thermal energy self-sufficiency

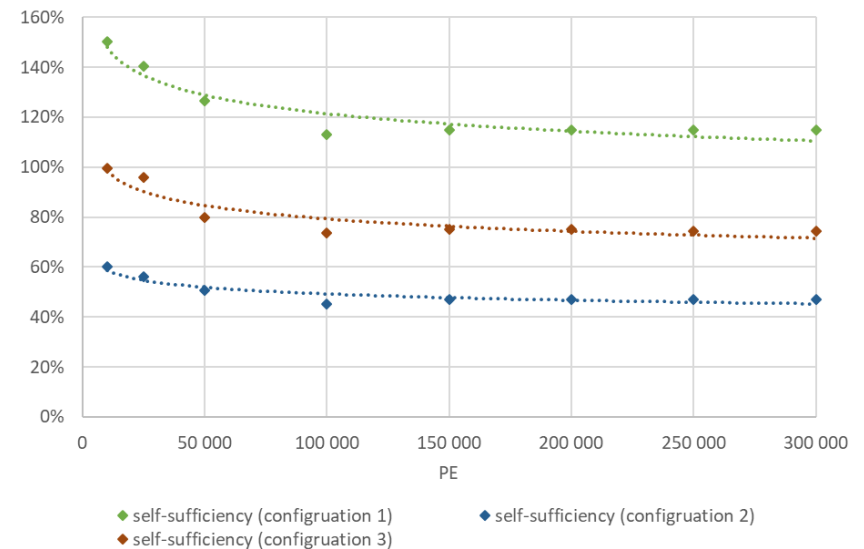

Configuration 1: Anaerobic WWTP + Digester gas CHP-unit

Configuration 2: Anaerobic WWTP + Digester gas CHP-unit + LT-Belt-dryer

Configuration 3: Anaerobic WWTP + Digester gas CHP-unit + LT-Belt-dryer + Gasification + Syngas CHP-unit

# OUTLOOK FOR STEP 3

## STEP 3: Daily dry weather load- and production profiles

- Generating a data pool by performing static simulations via OPTIEVLEX
  - Several waste water treatment system configurations
    - Aerobic treatment plants with gasification and combustion units
    - Combustion with/without ORC-Process
    - Gasification with a Syngas utilisation in a CHP-Unit or heating boiler
  - Different plant capacities
  
- Simulation of daily load- and production profiles

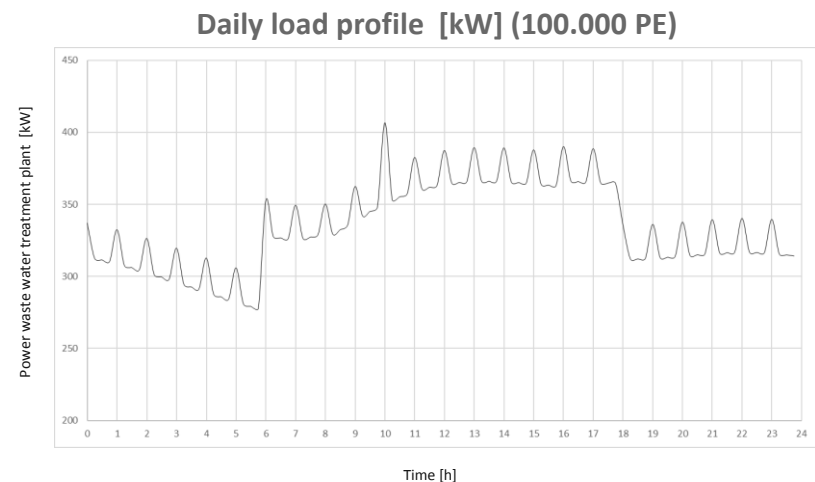

# OUTLOOK FOR STEP 4

## STEP 4: Maximum flexibility range

Five decisive factors concerning the flexibility potential

- High electric and thermal energy self-sufficiency
- Minimal available power
- Deactivation time and responds speed of the units
- Full-load hours of the units
- Availability of storage possibilities for digester gas and sewage sludge

Daily load profile [kW] (100.000 PE)

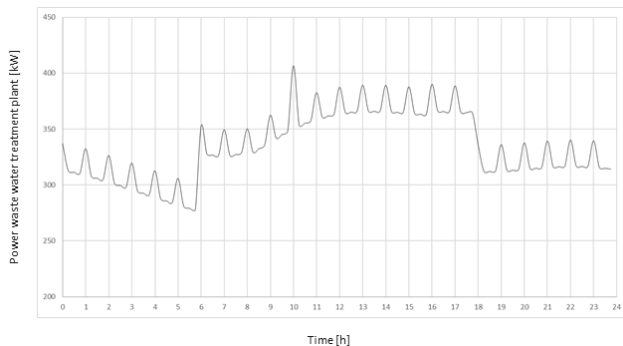

Maximum flexibility range [kW] (100.000 PE)

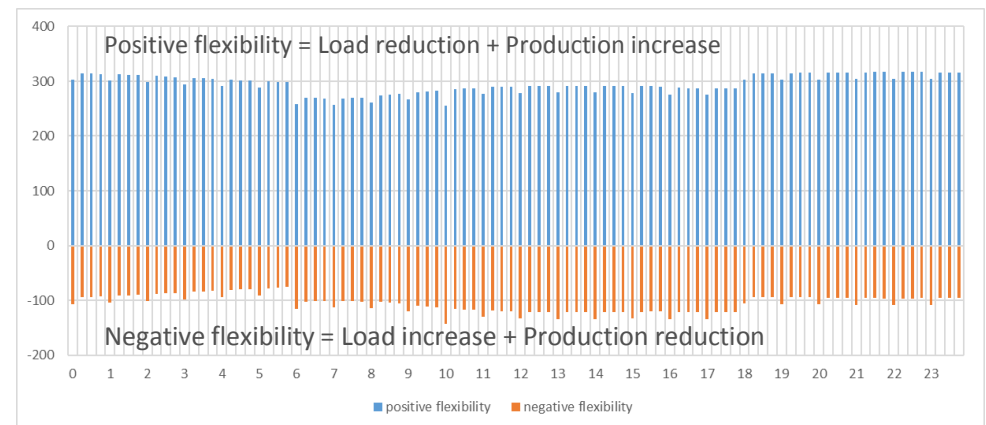

# OUTLOOK FOR OPTIEVLEX<sub>PLUS</sub>

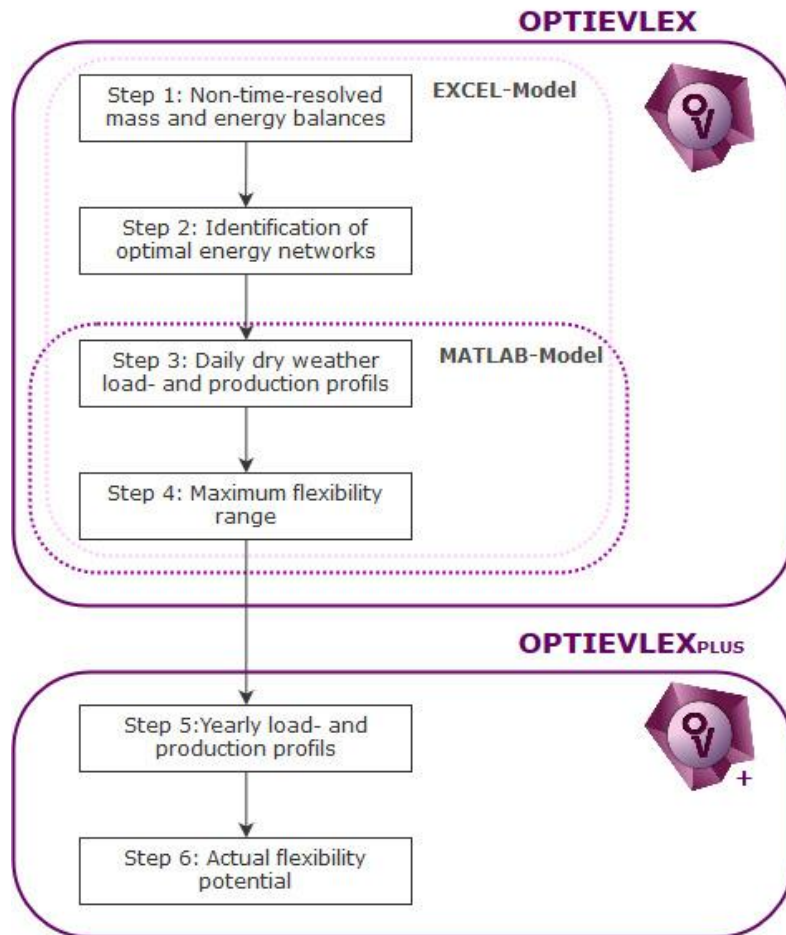

- Actual flexibility potential = ?
- Energy services = ?

## YEARLY LOAD- AND PRODUCTION PROFILES BASED ON TYPICAL METEOROLOGICAL DAY

- Identifying the actual flexibility potentials of a waste water treatment plant by constant purification performance
- Stabilization potential within the electric energy grid



THANK YOU FOR YOUR ATTENTION!

DEPARTMENT FÜR  
*Umwelt- & EnergieverfahrenSTECHNIK*



# REFERENCES

- (1) <https://www.istockphoto.com/ch/vektor/elektrischen-transformator-symbol-gm899783628-248278168>
- (2) [https://jp.123rf.com/photo\\_21295788\\_%E7%99%BD%E3%81%84%E8%83%8C%E6%99%AF%E3%81%AE%E4%B8%8A%E3%81%AE%E5%B7%A5%E5%A0%B4%E3%81%AE%E3%82%A2%E3%82%A4%E3%82%B3%E3%83%B3-%E3%83%99%E3%82%AF%E3%83%88%E3%83%AB-%E3%82%A4%E3%83%A9%E3%82%B9%E3%83%88.html](https://jp.123rf.com/photo_21295788_%E7%99%BD%E3%81%84%E8%83%8C%E6%99%AF%E3%81%AE%E4%B8%8A%E3%81%AE%E5%B7%A5%E5%A0%B4%E3%81%AE%E3%82%A2%E3%82%A4%E3%82%B3%E3%83%B3-%E3%83%99%E3%82%AF%E3%83%88%E3%83%AB-%E3%82%A4%E3%83%A9%E3%82%B9%E3%83%88.html)
- (3) <https://www.istockphoto.com/ch/grafiken/windenergie?assetfiletype=eps&mediatype=illustration&phrase=windenergie&sort=mostpopular>
- (4) <https://www.istockphoto.com/ch/grafiken/trafostation?assetfiletype=eps&mediatype=illustration&phrase=trafostation&sort=mostpopular>
- (5) <https://www.istockphoto.com/ch/grafiken/haus?assetfiletype=eps&mediatype=illustration&phrase=haus&sort=mostpopular>
- (6) <https://www.istockphoto.com/ch/grafiken/haus-mit-pv?assetfiletype=eps&mediatype=illustration&phrase=haus%20mit%20pv&sort=mostpopular>
- (7) <https://www.istockphoto.com/ch/grafiken/waste-water-treatment?assetfiletype=eps&mediatype=illustration&phrase=waste%20water%20treatment&sort=mostpopular>