

Universität Stuttgart

Institute for Building Energetics, Thermotechnology
and Energy Storage



**From Lab to Grid
OPERATING A
SORPTION HEAT STORAGE SYSTEM
IN A DISTRICT HEATING NETWORK**

ISEC Conference

14. - 16.04.2026

Graz, Austria

Overview

Aim of the Heat2Share project

- Further development of a thermo-chemical energy storage system

➔ What is special about thermo-chemical energy storage?

Energetic point of view:

- enables new storage applications
- high storage densities (kWh/m³)
- minor heat losses
- can be customized through the choice of storage material

Scientific point of view:

- very complex and dynamic heat and mass transfer processes
- technology is quite demanding,
- it is very complex in terms of equipment, as the system is operated at negative pressure.



B & O Bau und Gebäudetechnik GmbH & Co. KG



BEB - BioEnergy Berlin GmbH



From Lab to Grid

Aim and history of the project Heat2Share

- the project is a retrospective look at the development of thermochemical energy storage
 - Based on the consortium's experience from a number of previous projects starting point TRL 4 → achieving TRL 6 -7
- Verification of a thermo-chemical heat storage System
 - System testing in a real environment
 - Integration in an existing district heating network



B & O Bau und Gebäudetechnik GmbH & Co. KG



BEB - BioEnergy Berlin GmbH



Development of a thermochemical heat storage system

- System under investigation works according the principle of closed adsorption

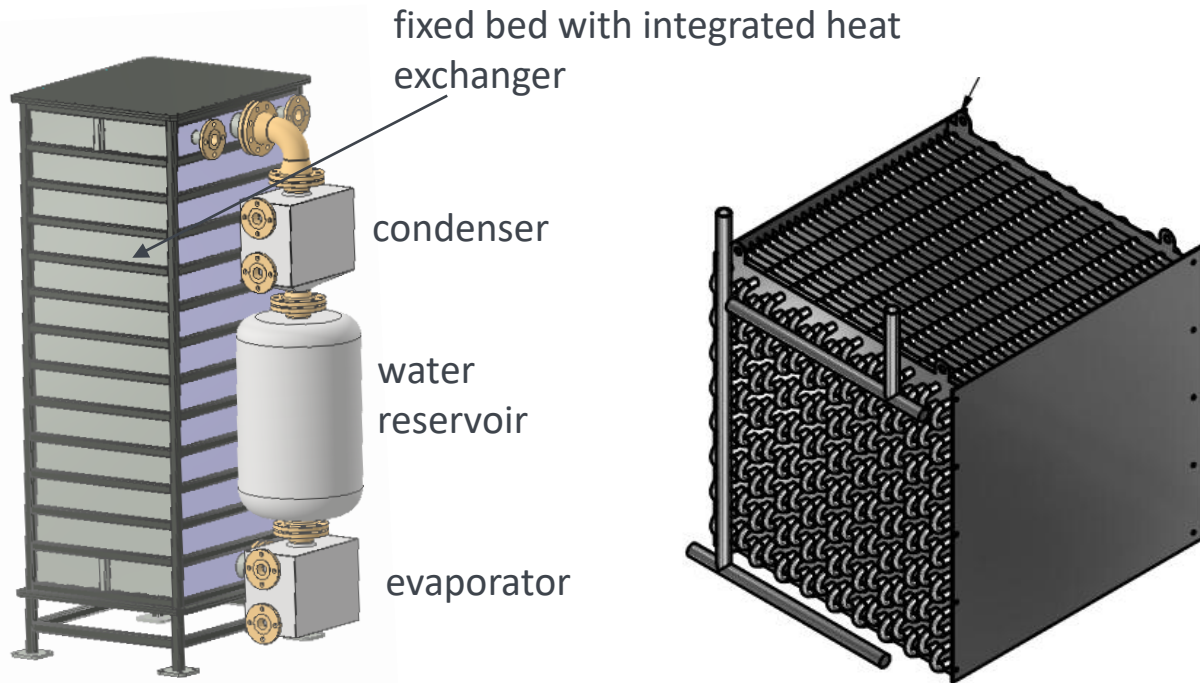

activated carbon impregnated
with calcium chloride
cylindrical grains from ~ 2 - 3 mm

Heating network of Barenthin



- network length: 3 km
- 29 consumer/buildings
- biogas plant + CHP
- heat demand ca. 1100 MWh/a
- flow/return temperature of network is ~ 70/55 °C
 $\Delta T \sim 15 \text{ K}$

CHP MTU

- thermal power: 420 kW
- electric power: 360 kW

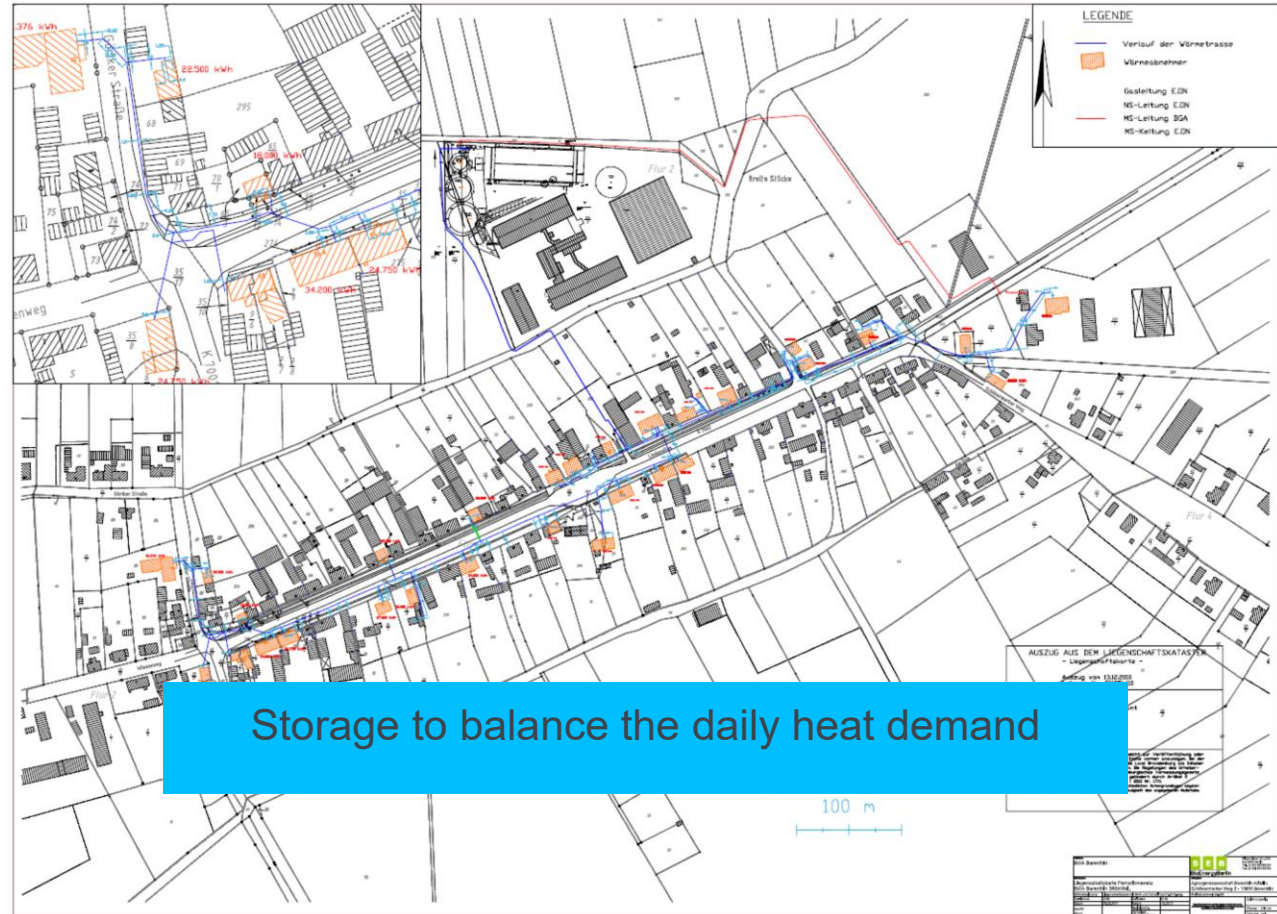

System design

compact, modular and scalable Unit

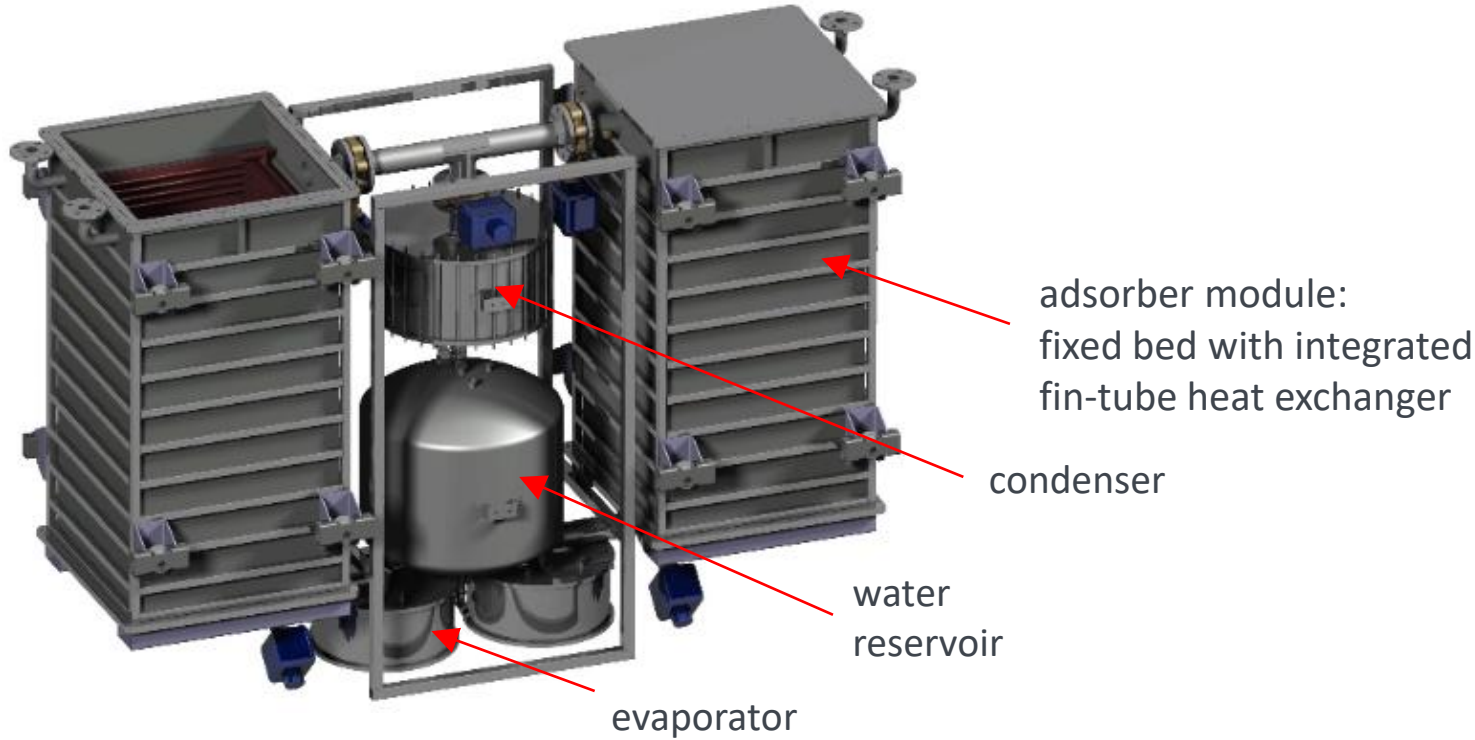

Reactor vessel and heat exchanger



Vacuum tightness is the challenge

Construction of Evaporator and Condenser

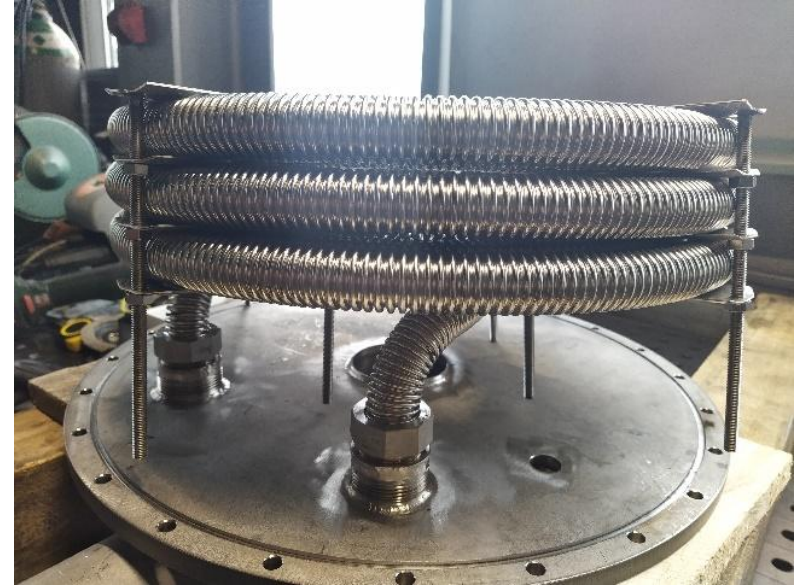

Power and compactness is the challenge

System design

2 x 2 Modules installed in a container ready to connect

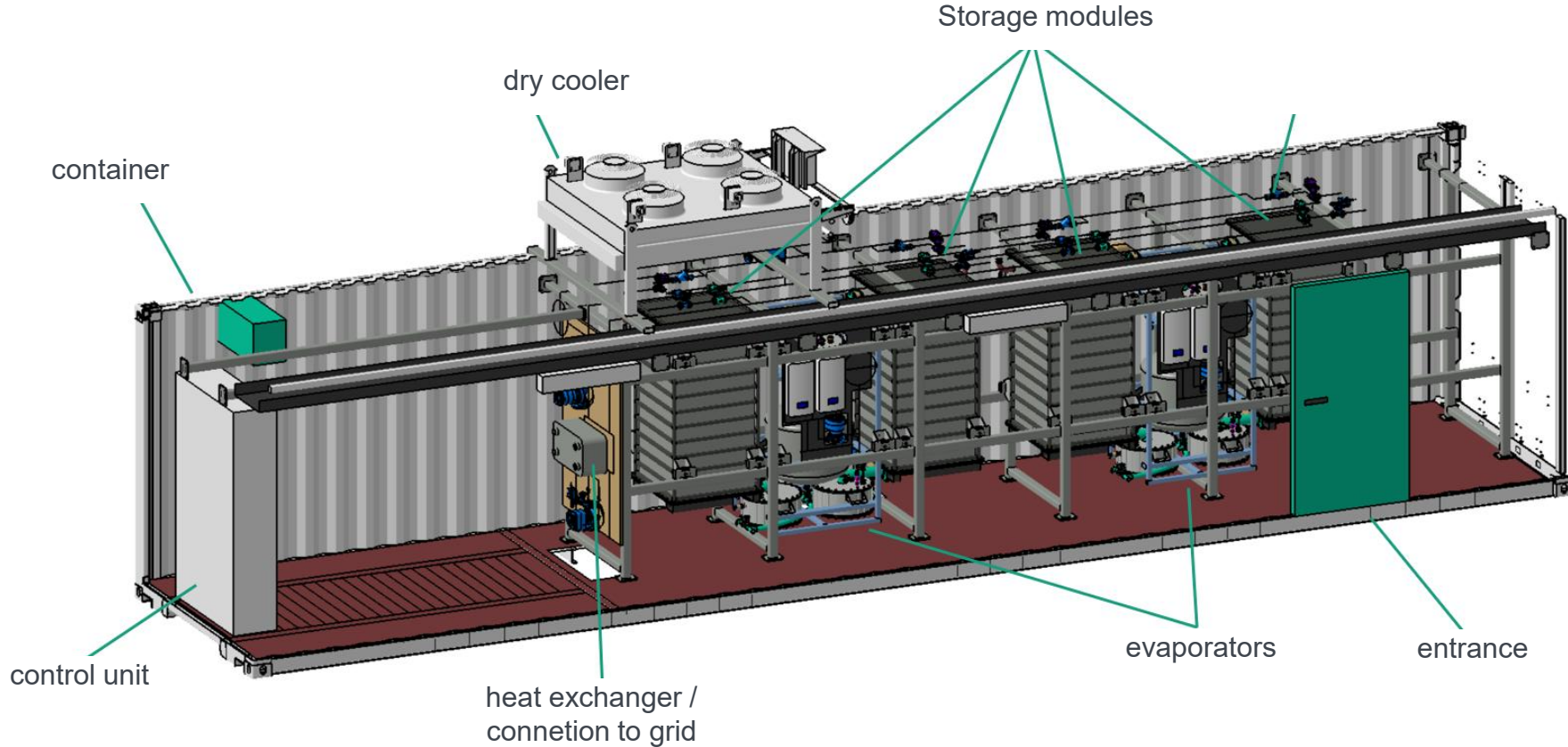

Container in Barenthin



Look inside the container



Hydraulic connection of storage system

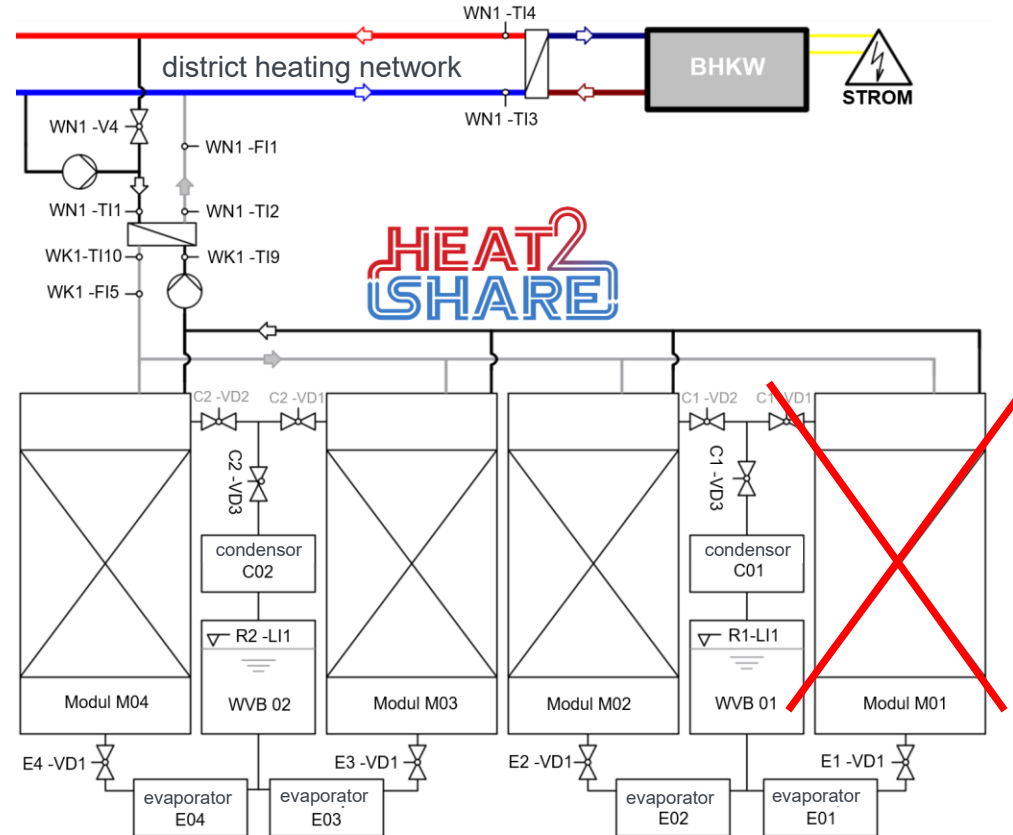

Experimental Results

Desorption – Storage charging

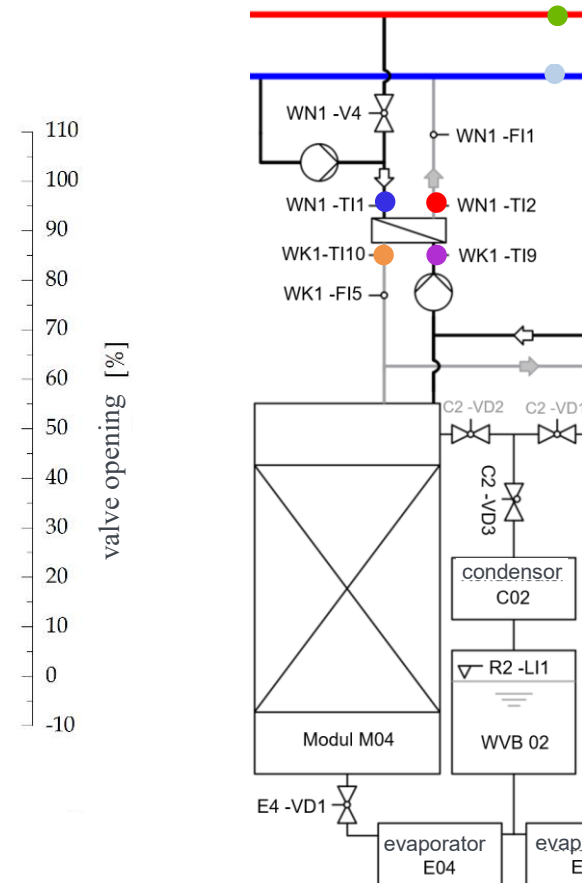
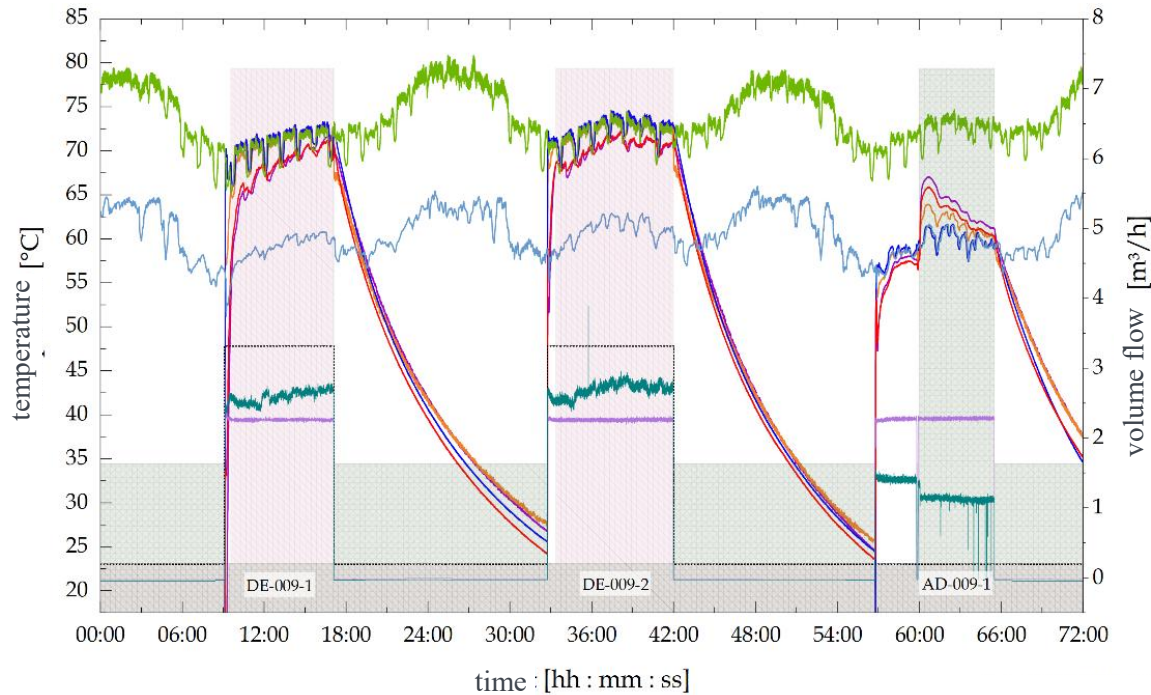

Experimental Results

Desorption – Storage charging

amount of water desorbed: 64 kg → 61 kWh thermal energy @ $\Delta T \sim 15$ K

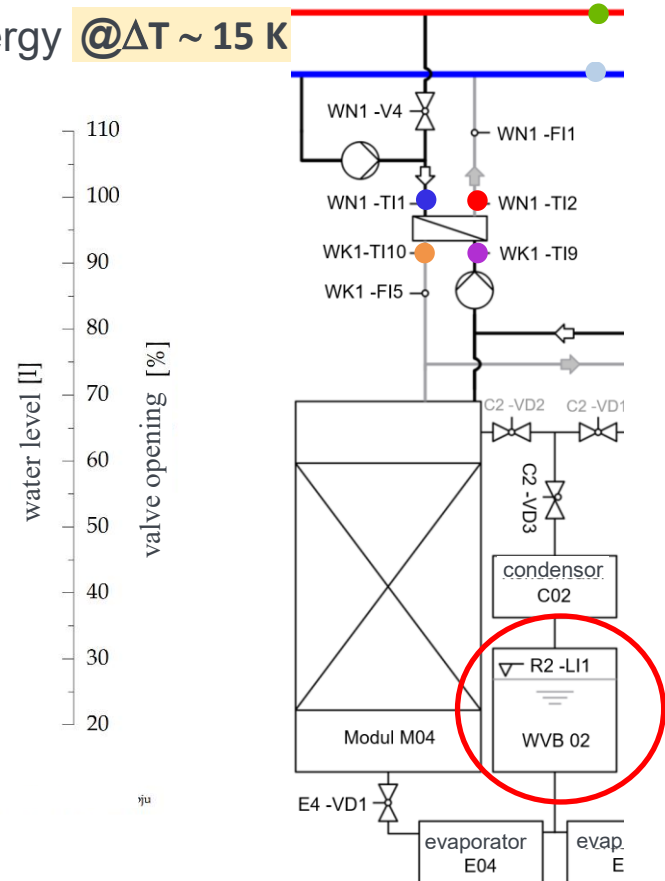
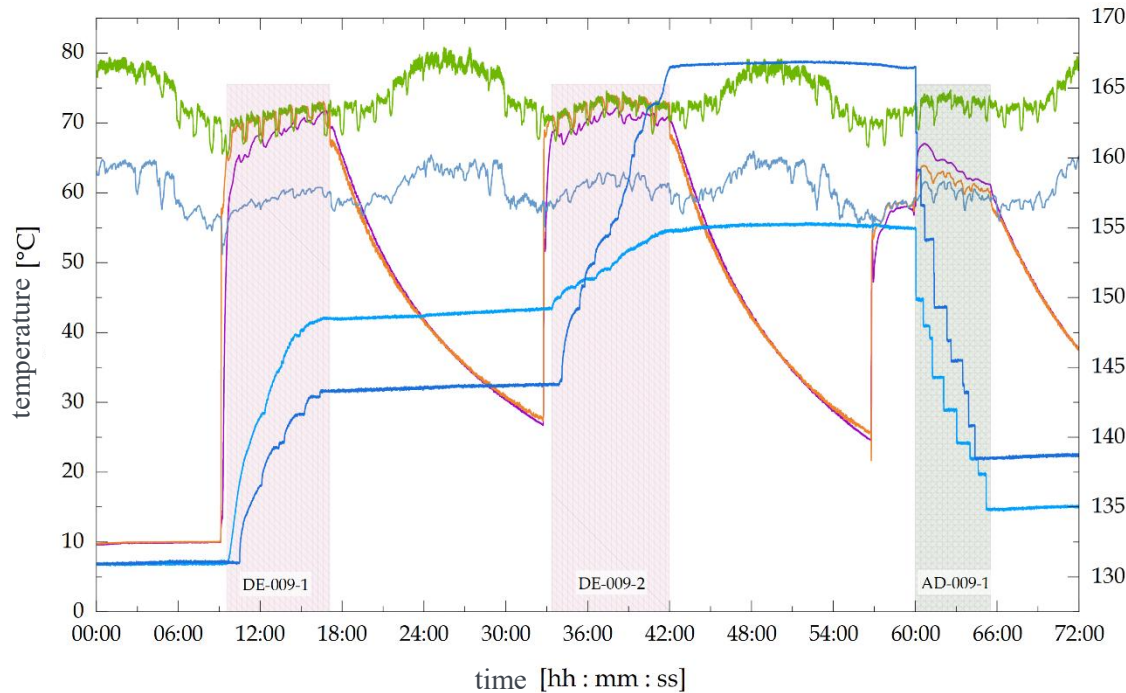

Experimental Results

Desorption – Storage charging

amount of water desorbed: 64 kg → 61 kWh thermal energy @ $\Delta T \sim 15 \text{ K}$

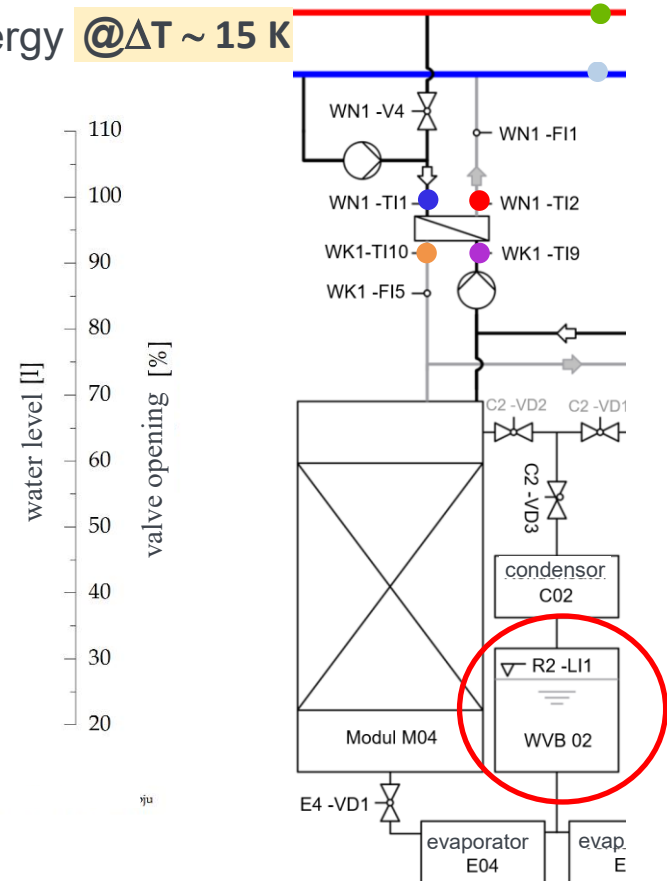
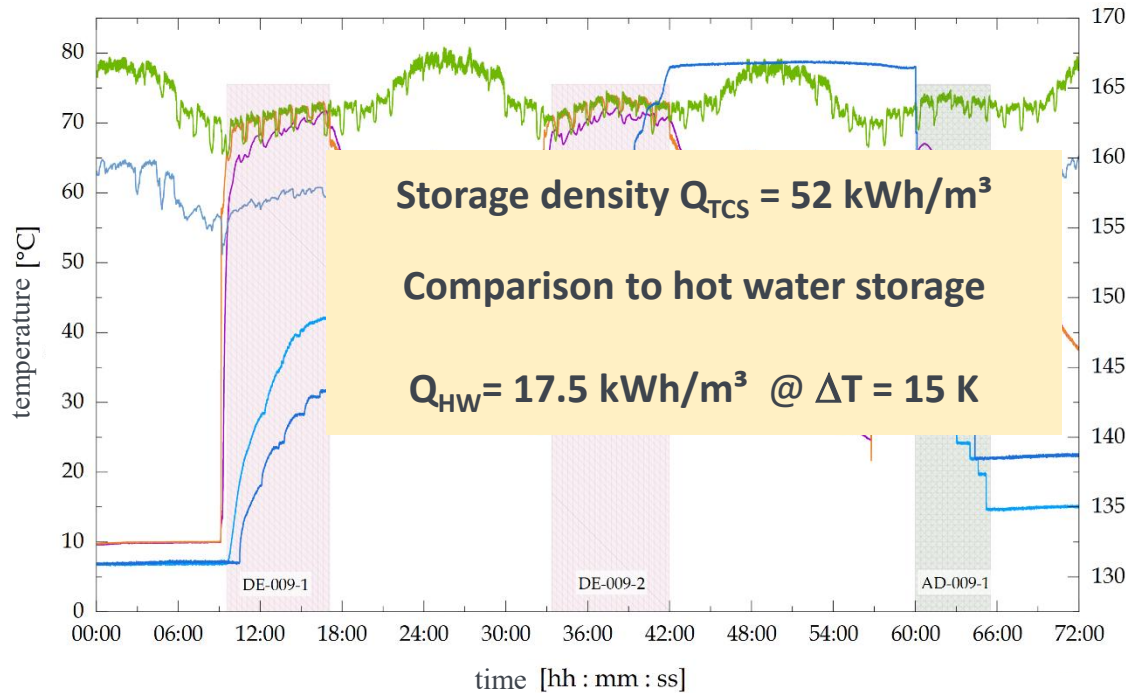

Experimental Results

Adsorption – Storage discharging

Discharge is implemented via return temperature elevation

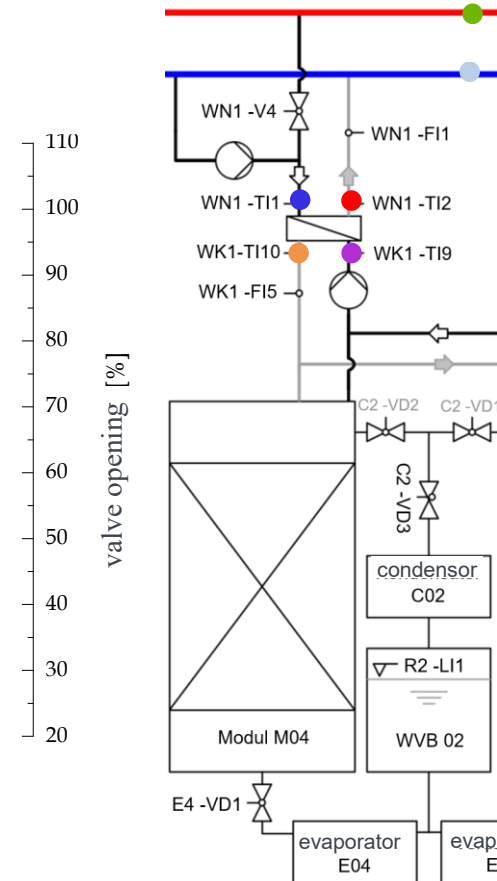
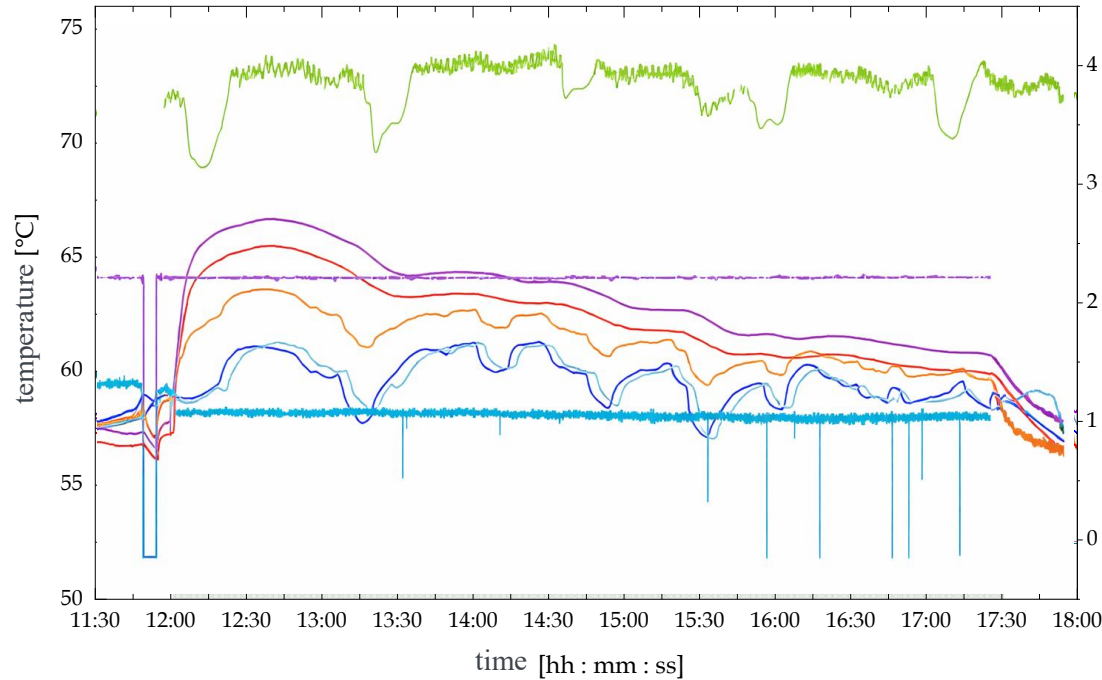

Summary



Status of the System

- Based on years of experience, we have developed an advanced thermochemical storage system
- System is implemented in Barenthin
- fully connected to the district heating network
- System in operation (3/4 modules) since July 2025
- Experimental data show good performance
- Adsorption and Desorption work as expected
- Storage density measured: 52 kWh/m³ (at $\Delta T = 15$ K!)

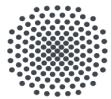

Universität Stuttgart

Institute for Building Energetics,
Thermotechnology and Energy Storage



Thank you for your attention



Dr.-Ing. Henner Kerskes

E-Mail henner.kerskes@igte.uni-stuttgart.de

Telefon +49 (0) 711 685-63534

Universität Stuttgart

Pfaffenwaldring 6, 70569 Stuttgart

Supported by:



Federal Ministry
for Economic Affairs
and Climate Action

on the basis of a decision
by the German Bundestag

Hydraulic integration

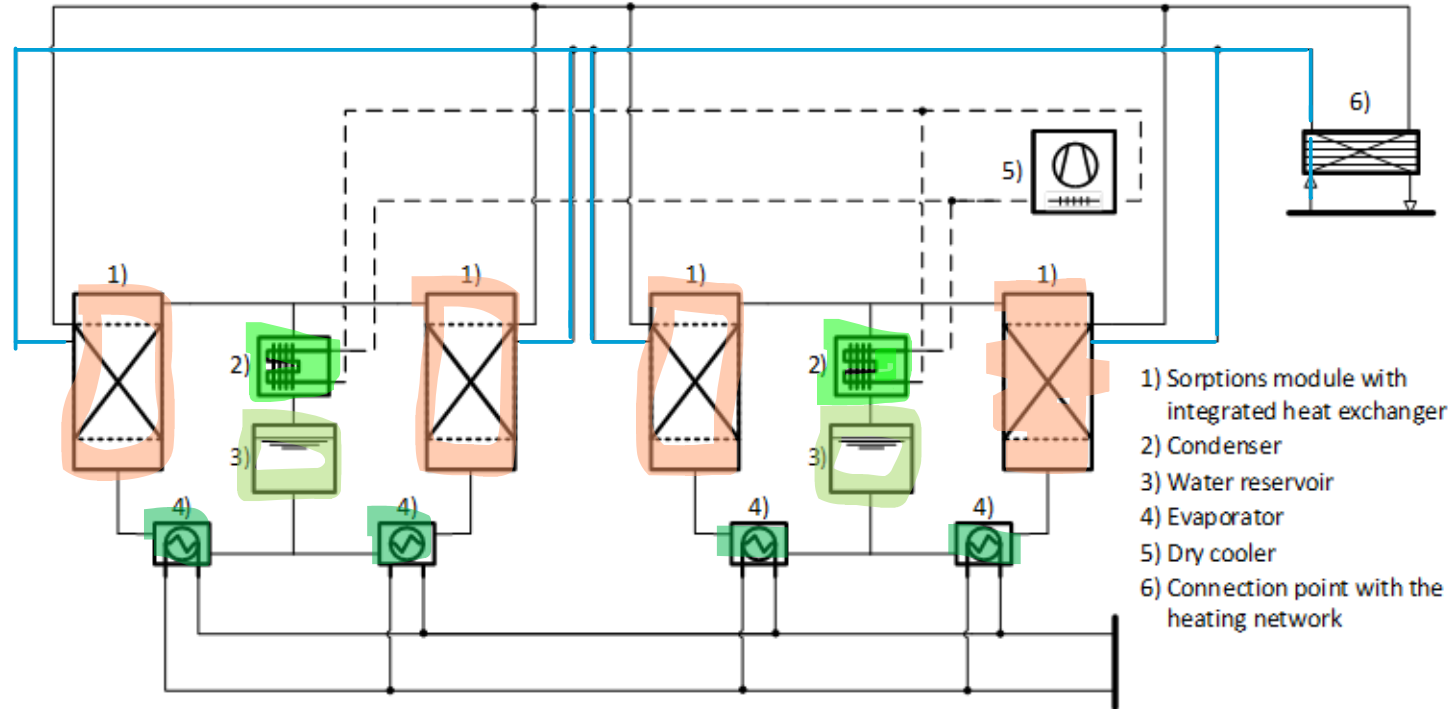

Storage System plant

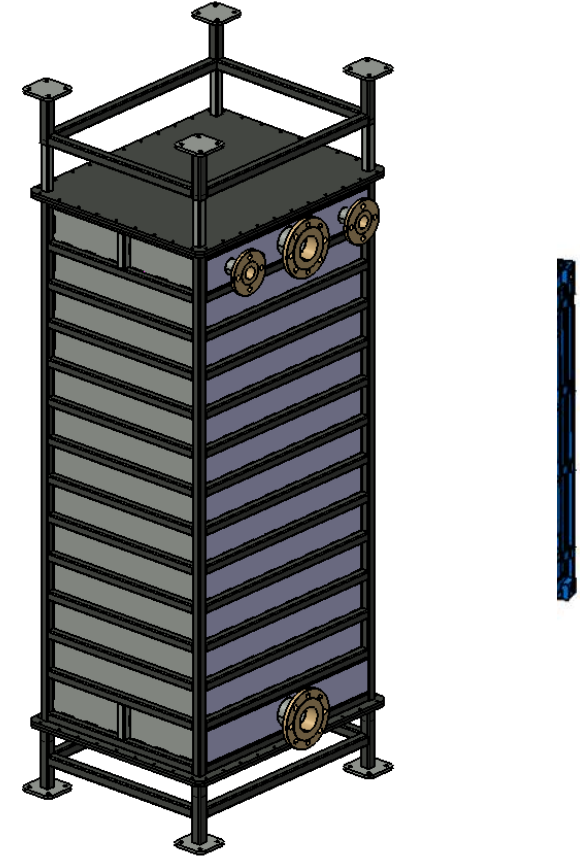
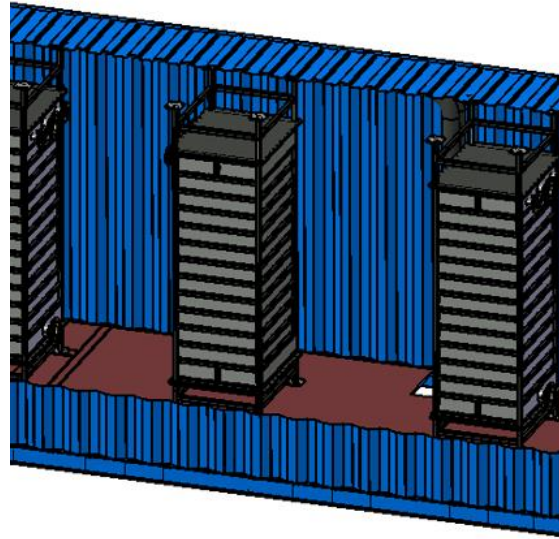
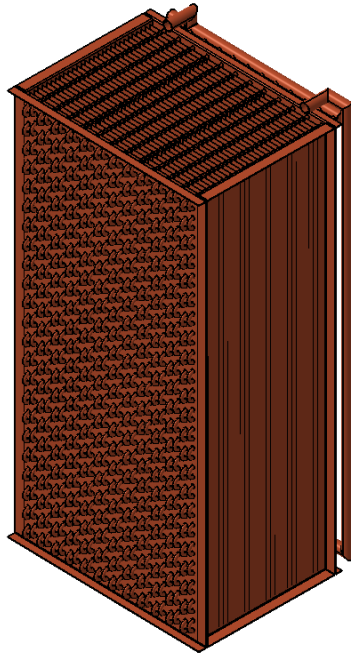

Experimental Results

Desorption

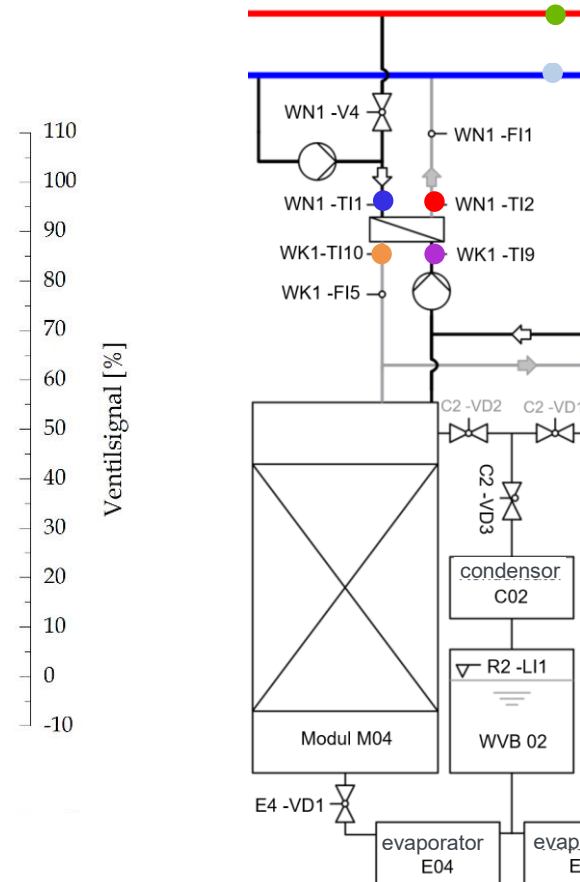
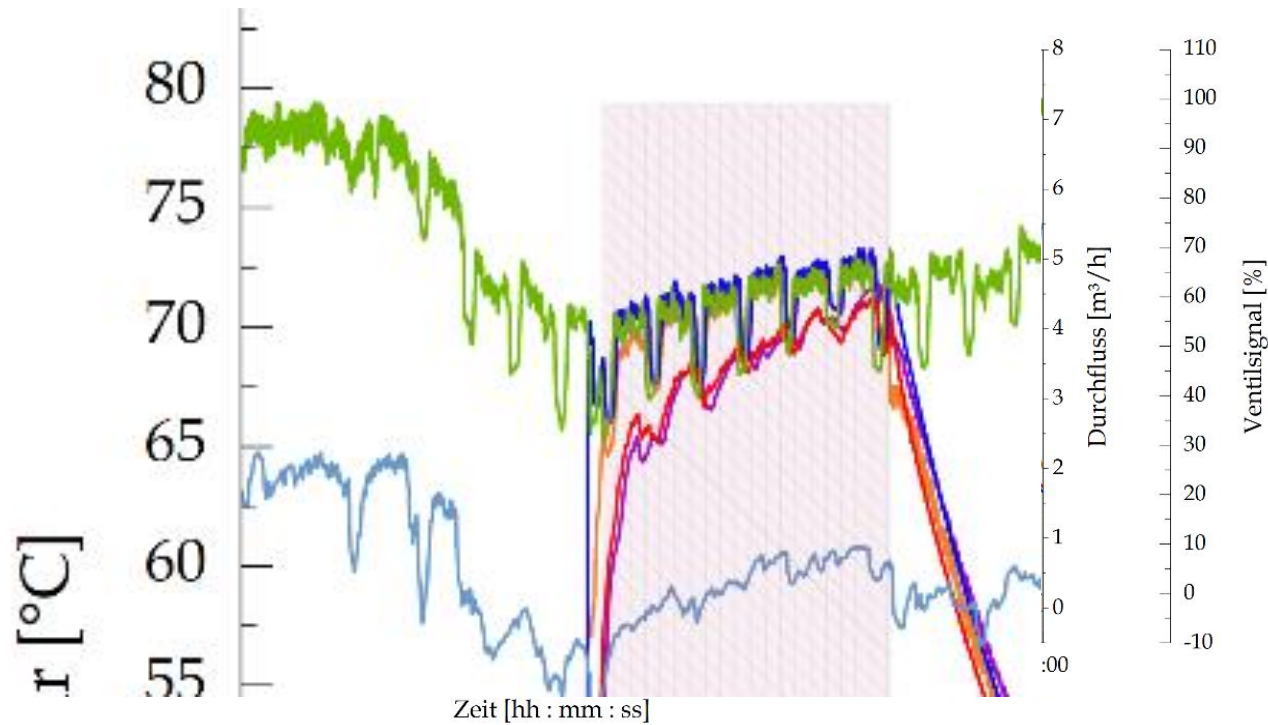

Optimization of heat and mass transfer

Transient inlet value for the simulation from experiments

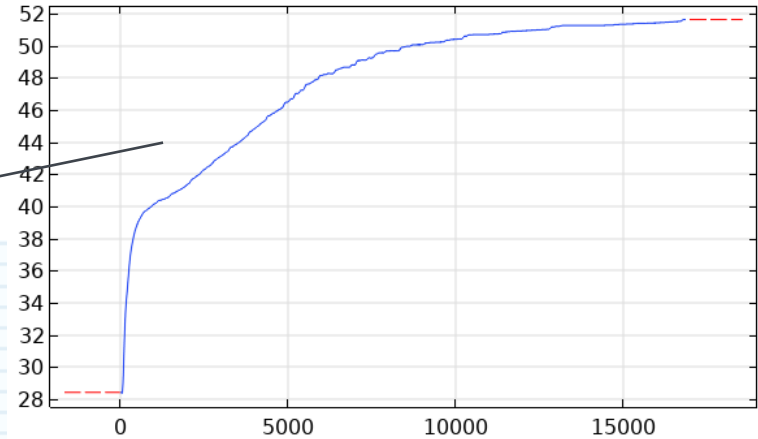
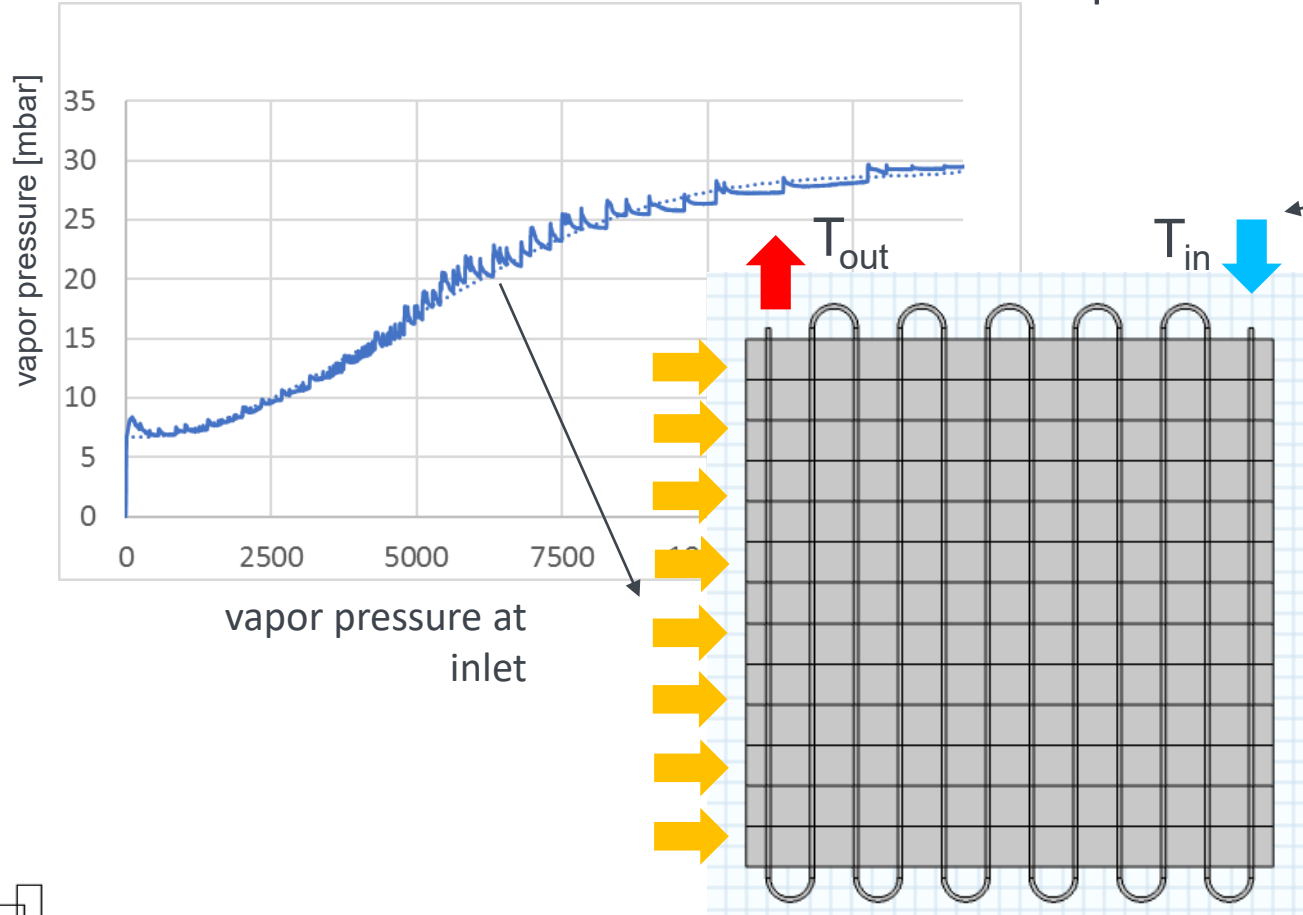

temperature profile at inlet of heat exchanger

Optimization of heat and mass transfer

Power output of the store



Variation of distance between fins

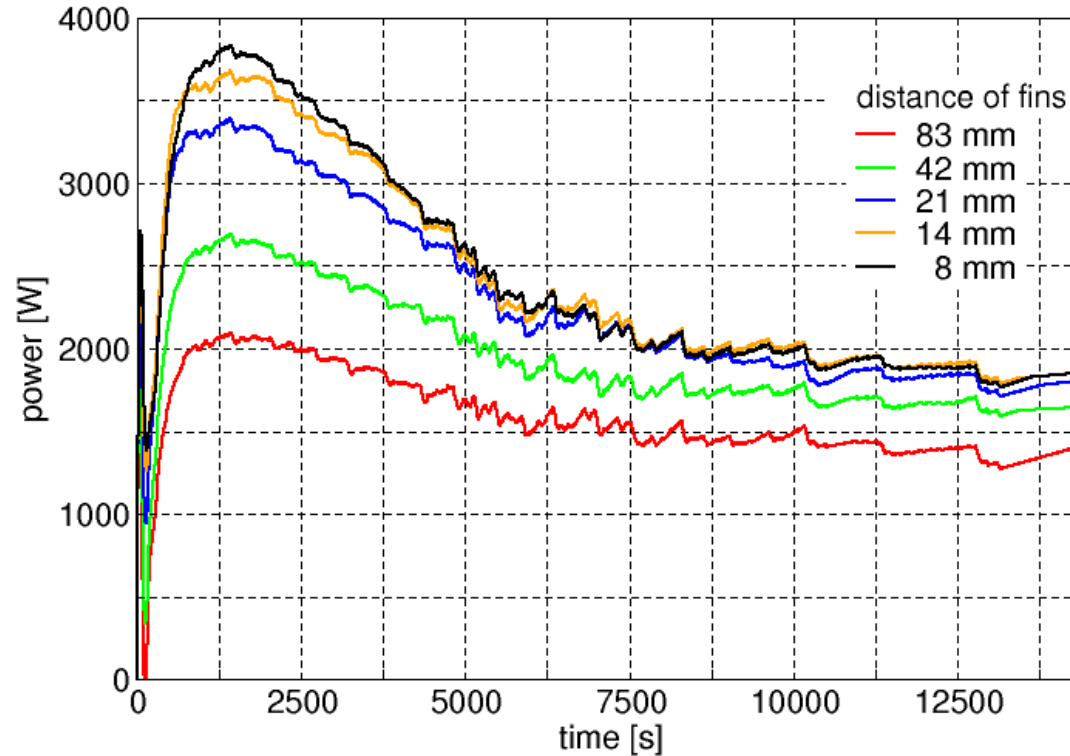

Water-Isotherms* of CaCl₂ - activated carbon

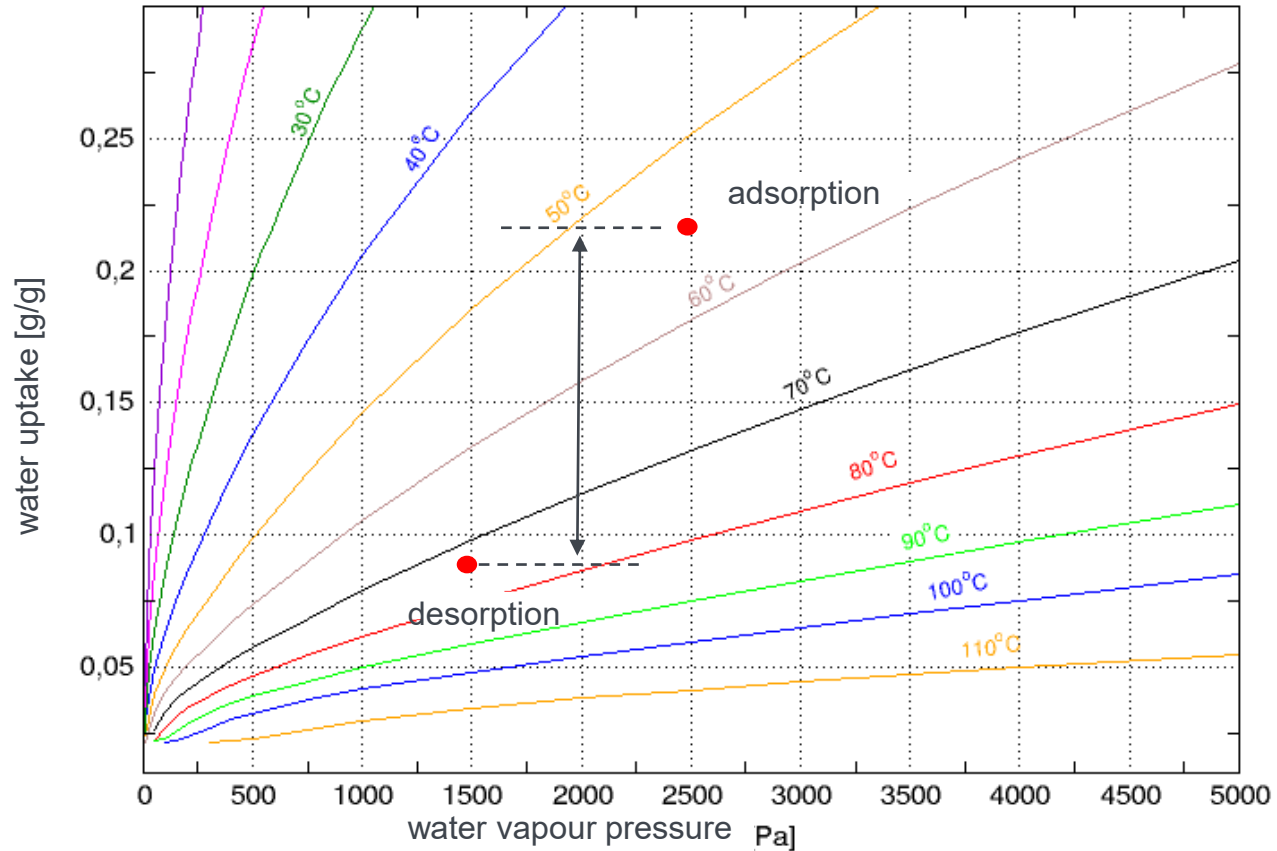

*calculated from Muggel data