

Hydrogen-Fuelled Combined Heat and Power for District Heating

Andreas Patha, AIT, andreas.patha@ait.ac.at

Felix Hubmann, AIT, felix.hubmann@ait.ac.at

Bernhard Thaler, LEC, bernhard.thaler@lec.tugraz.at

Clement Leroux, INNIO Jenbacher, clement.leroux@innio.at

System overview and boundary conditions

Boundary conditions & energy prices:

- Heat demand for local district heating network (2024)
- Electric Day-Ahead-Market (2024)
- Constant hydrogen price
- Competitive heat source with constant price

Assumptions for CHPs:

- Minimum On-time of 4 h
- Only full power

Simulation approach:

- Simulation using non-linear models
- Linear optimization in order to reduce costs

Parameterstudy:

- Hydrogen price
- Price of competitive heat source

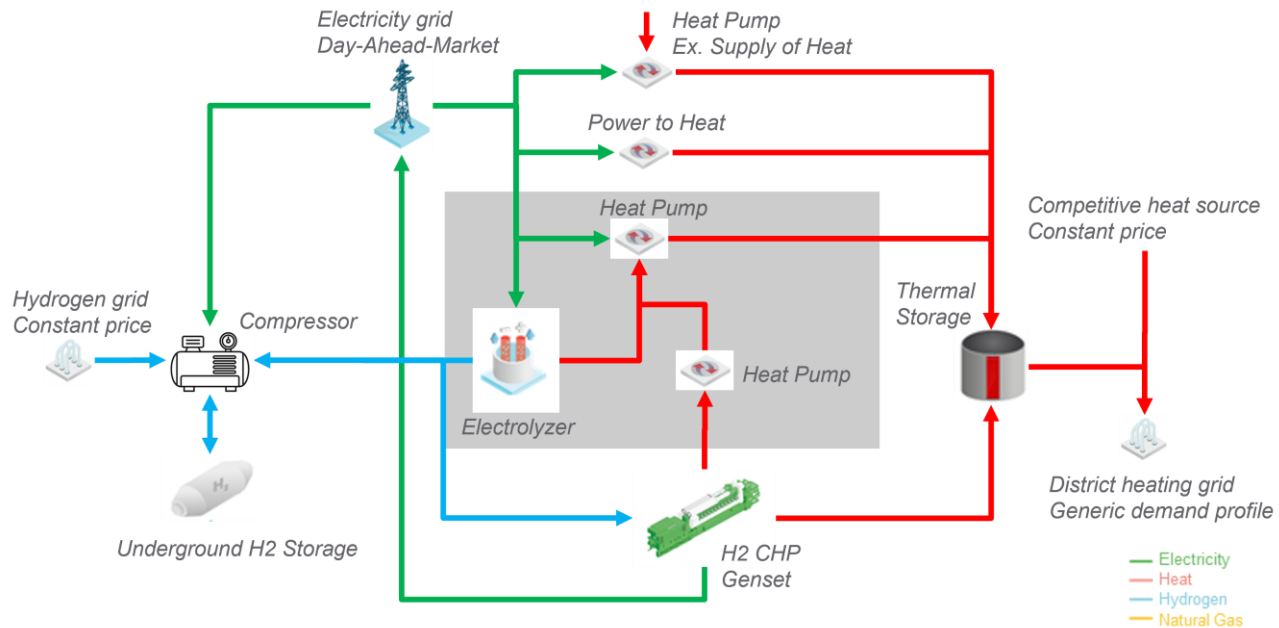

Component	Nominal power	Nominal capacity	Nominal efficiency
Combined heat and power	200 MW_{th} 191 MW_{el}	/	(a)
PEM-Electrolyzer	40 MW_{el}	/	(a)
Heat pump CHP	(b)	/	$\eta = 60\%$ 30 °C → 60 °C
Heat pump electrolyzer	(b)	/	$\eta = 60\%$ 60 °C → 115 °C
Heat pump sea water	60 MW_{el}	/	$COP_{eff,avg} = 2.68$
Power to heat	30 MW_{el}	/	$\eta \approx 96.7\%$
H ₂ -Compressor	/	/	1.5 kWh_{el}/kg_{H_2}
H ₂ -Storage	/	$V \approx 450 \cdot 10^3 m^3$ $p_{nom} = 40 bar$	/
Thermal storage	$n \cdot 200 MW_{th}^{(c)}$	$d = 30 m$ $h = 40 m$ $n = 2$	/

(a) Physical model with power dependent efficiency

(b) Unlimited

(c) With flow temperature 115 °C and return temperature 60 °C

Grid	$P_{max}^{feed-in} / MW$	P_{max}^{draw} / MW
Electricity	200	100
Hydrogen	0	460
Heat	-	0

Heat demand for local district heating network

Generic heat demand profile using hotmaps dataset

- Weather data
- Day time
- Weekday
- Month

Scaled to annual demand of Kiel (~ 1 TWh/a)

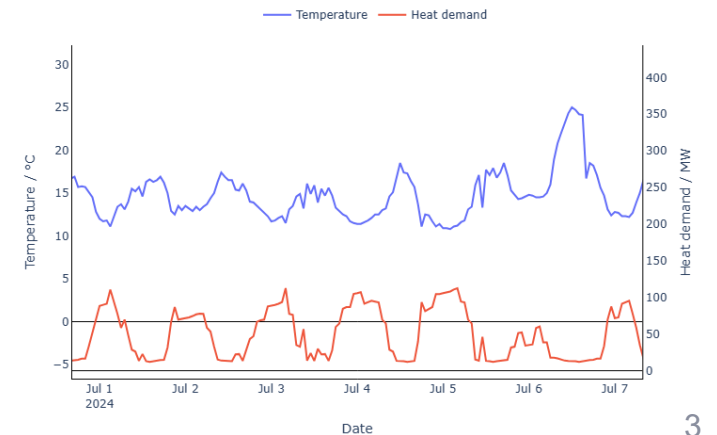
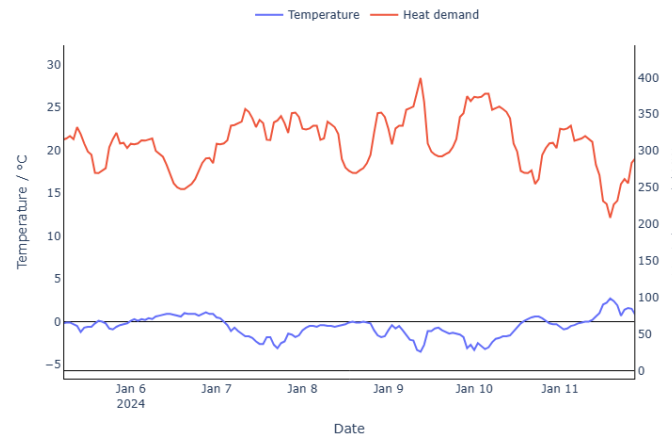
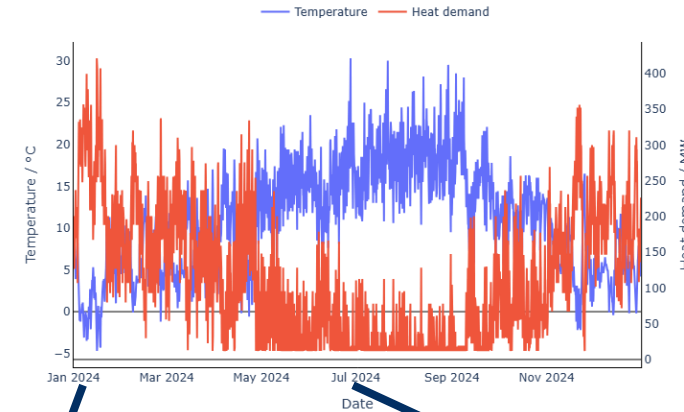

Simulation Approach

Technical Model

- On technology level
- Non-linear representation as physical or data-driven model

Optimisation Model

- Mixed integer linear problem
- Abstraction of technical model
- Only operational optimization
- Target function: Minimization of costs

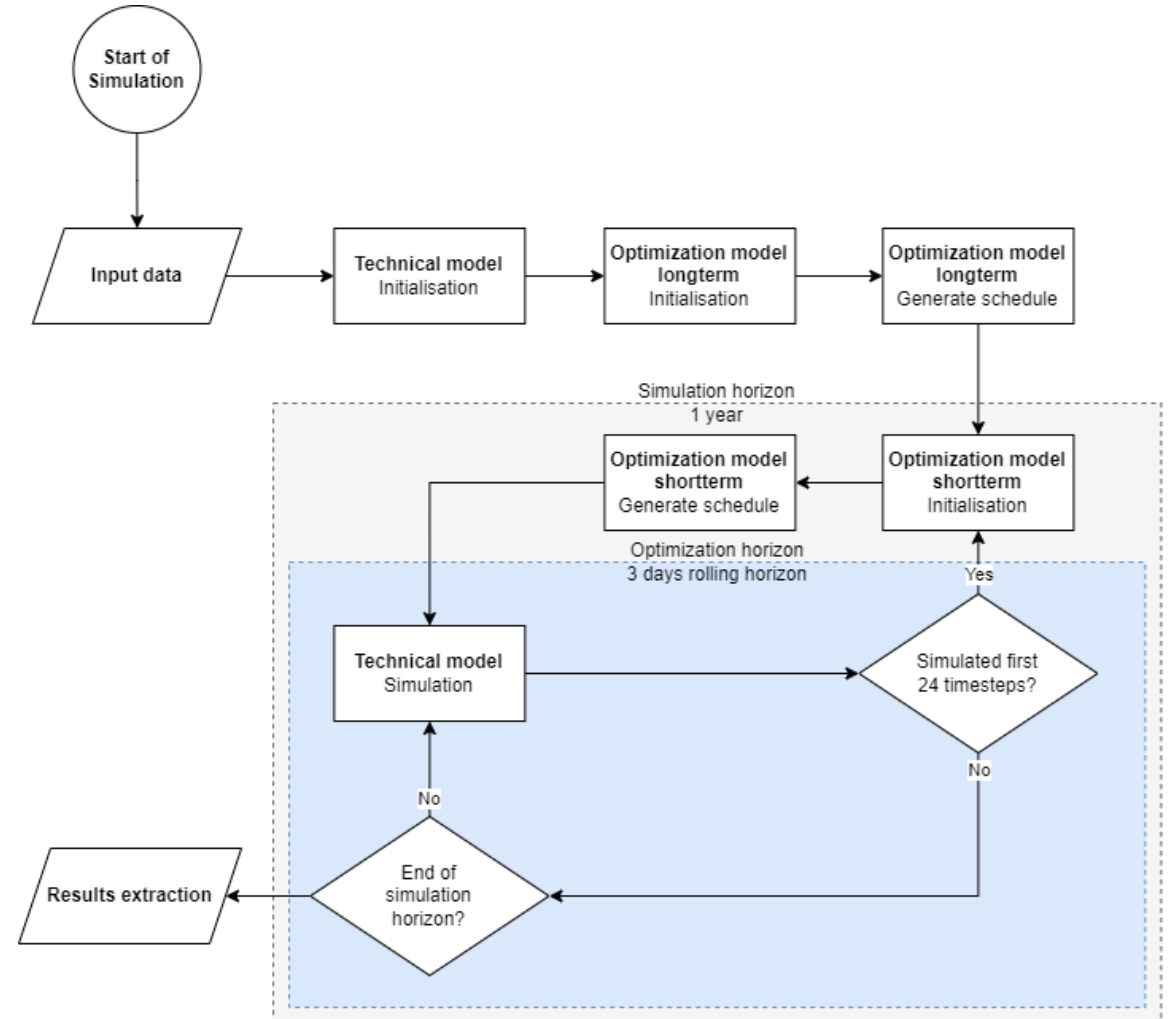

Plant-internal competition

Low H2 price = 1 €/kg

High competitive heat price = 80 €/MWh

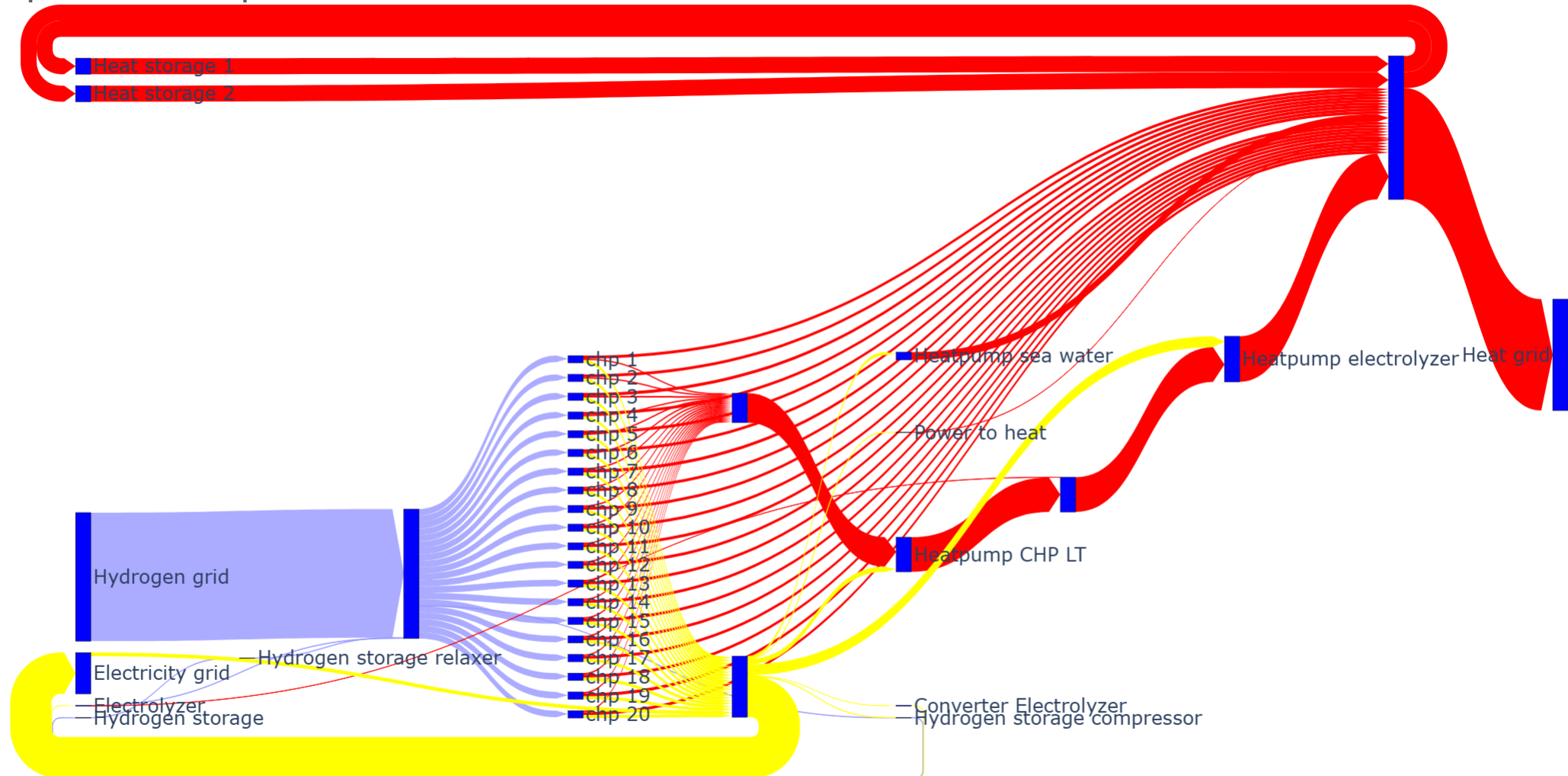

Plant-internal competition

High H2 price = 5 €/kg

High competitive heat price = 80 €/MWh

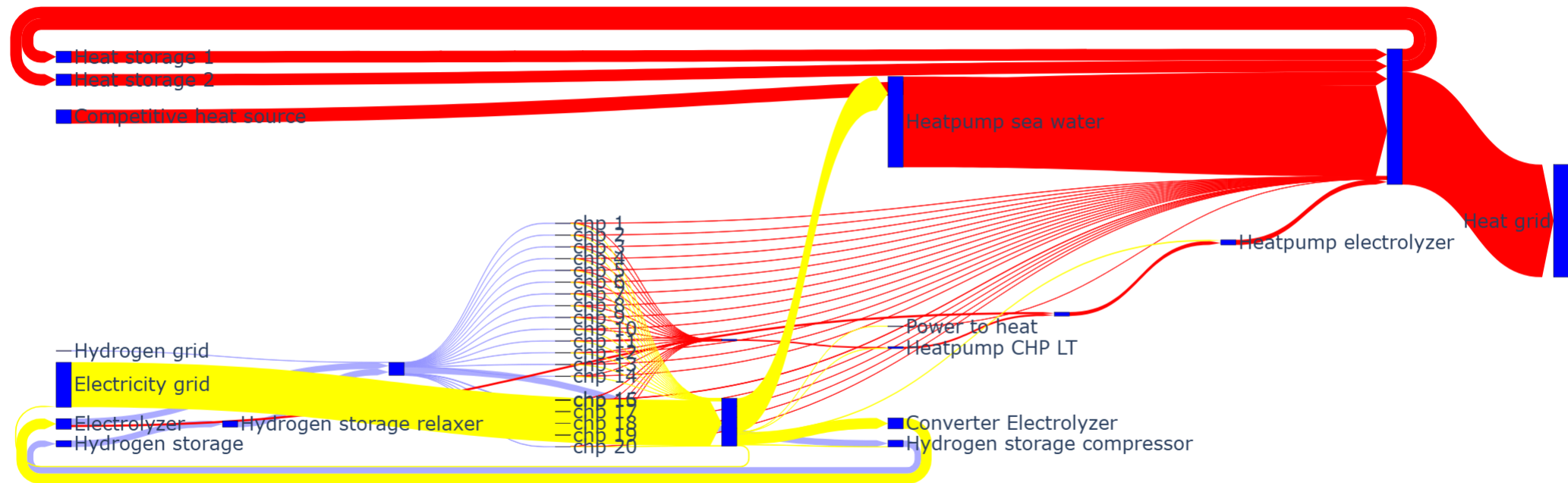

Overall competition

Techno-Economic Results

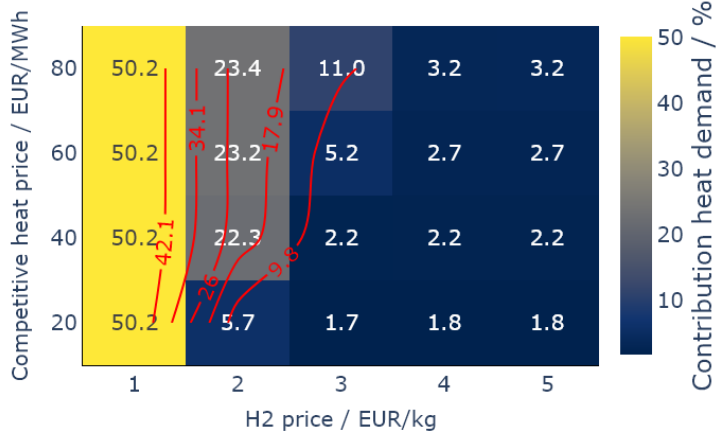

(a) H2-CHP genset high temperature output

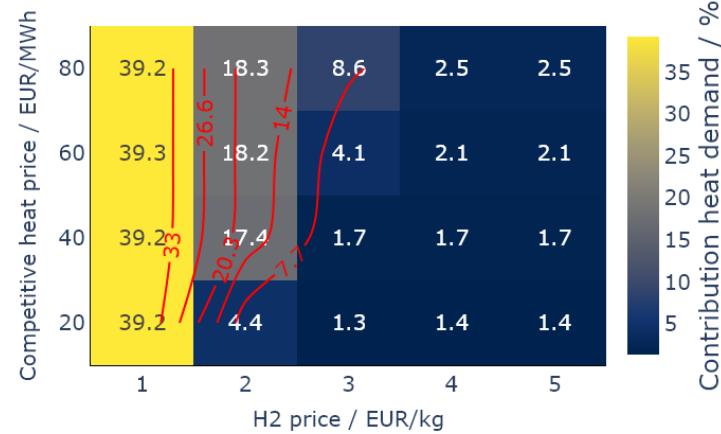

(b) H2-CHP genset low temperature output

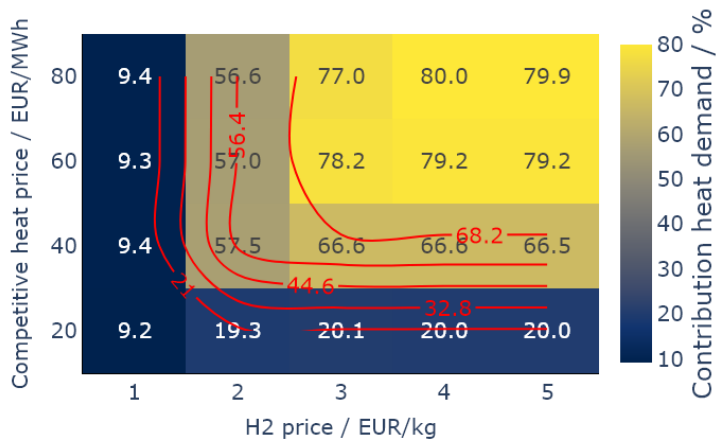

(c) HP sea water

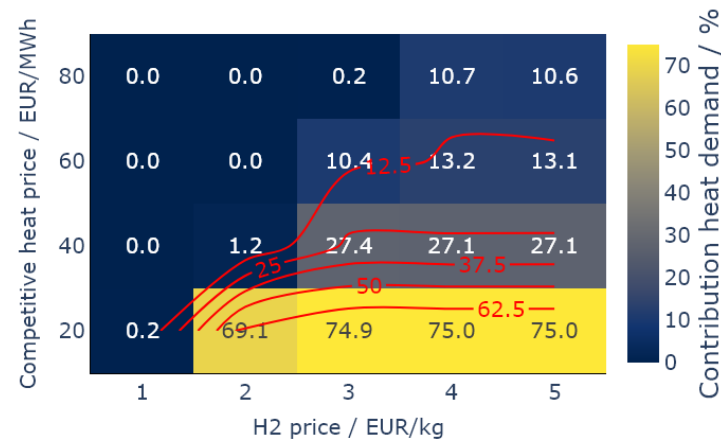

(d) Competitive heat

- Increasing share by CHPs for decreasing hydrogen price < 3 €/kg_{H2}
- Remark: Only Day-Ahead (2024) trading is considered!
- Ratio of CHPs upgraded LTH compared to HTH at roughly 78 %
- Sea water heat pump for high prices of competitive heat and hydrogen
- Competitive heat source for low prices of competitive heat and high prices of hydrogen
- Contribution by Electrolyzer and P2H are negligible

Discussion

- Dispatch of CHPs starts for hydrogen prices $< 3 \text{ €/kg}_{\text{H}_2}$
 - Only marginal cost analysis, no evaluation of economic viability (CAPEX, OPEX) → break even point for economic dispatch starts at lower hydrogen costs
- Limitations of the simulation approach
 - Only Day-Ahead-Market (based on historic DA-profiles) considered for electric energy:
 - Future price peaks in DA-profile and dark doldrums not modeled
 - Capacity mechanisms might change dispatch

Hydrogen-Fuelled Combined Heat and Power for District Heating

Andreas Patha, AIT, andreas.patha@ait.ac.at

Felix Hubmann, AIT, felix.hubmann@ait.ac.at

Bernhard Thaler, LEC, bernhard.thaler@lec.tugraz.at

Clement Leroux, INNIO Jenbacher, clement.leroux@innio.at